

# GENERATOR POWER OPTIMISATION FOR A MORE-ELECTRIC AIRCRAFT BY USE OF A VIRTUAL IRON BIRD

C. Schallert, A. Pfeiffer, J. Bals  
 German Aerospace Centre  
 82234 Wessling, Germany

**Keywords:** *electric supply system, generator design power, overload capability, aircraft systems model library, optimisation algorithm*

## Abstract

A procedure is developed to minimise the generator design power within the electric power system of a future more-/all-electric aircraft. This allows to save weight on the generators and on other equipment of the electric power system. Execution of the optimisation procedure by hand demonstrates the complexity of the problem. An automation of the process shows the capabilities of integrated modelling, simulation and optimisation tools.

## 1 Introduction

### 1.1 General Overview

Today civil aircraft systems are powered by hydraulic, electric and pneumatic energy, as depicted in Fig. 1. New developments in the field of aircraft systems follow the concept towards a "More-Electric Aircraft" (MEA). Pneumatically and hydraulically operated systems are replaced stepwise by electrically powered systems, in order to reduce their power demand and to lower the aircraft operating cost as an effect of improved efficiencies, reliability and eased maintenance. The European Community has established the project "Power Optimised Aircraft" (POA) to promote the development of more-electric aircraft systems and architectures [1]. Within POA, a virtual assessment and optimisation of aircraft system architectures by means of a dedicated simulation facility (Virtual

Iron Bird, refer to chapter 3.1) contribute to advancing the new developments.

Particularly with regard to future more-/all-electric aircraft, this paper presents an optimisation procedure developed for the purpose of minimising the design power and thus the weight of the on-board electrical generators.

The optimisation procedure draws upon the modelling and simulation of the power behaviour of entire aircraft system architectures, as well as the use of advanced tools for an automation of the process.

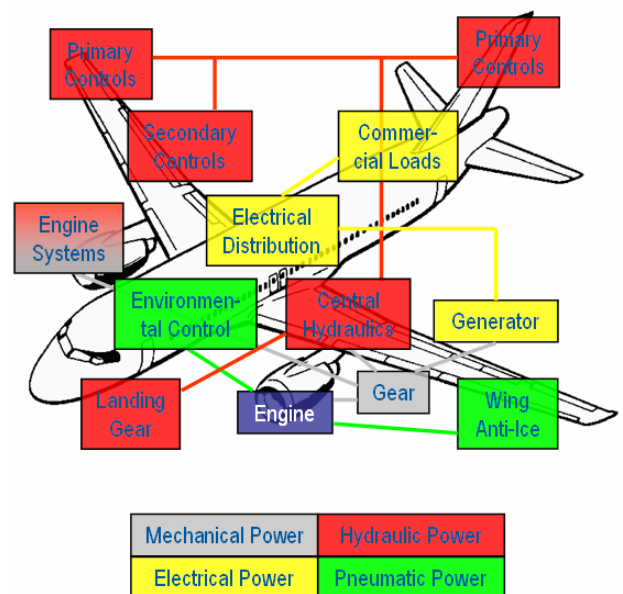

Fig. 1. Present Aircraft Systems Architecture

## 1.2 Present and Future Airborne Power Supply Systems

At present, consumers being powered by central hydraulic or pneumatic supplies typically are flight controls, landing gears and environmental control (refer to Fig. 1). If these consumers are electrified on a future aircraft, the electrical network has to take over the function of the former central hydraulic and pneumatic supplies, which then are removed (refer to Fig. 2). As a consequence, the electrical system has to generate more power, and also it has to be more reliable, since it supplies an increasing number of components having a safety critical function, e. g. flight control actuators.

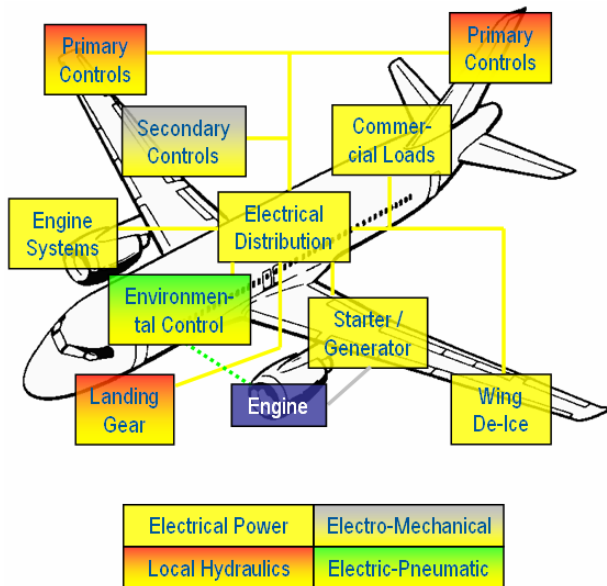

Fig. 2. A Potential Future More-Electric Aircraft Systems Architecture

Today's twin engine passenger jets have electrical systems including two engine driven generators. Due to increased demands for power and reliability, a viable electrical system design for a future aircraft of this category will have to include four engine driven generators, i.e. two per engine. In such an engine design, one generator is driven by the low-pressure (LP) shaft. The other machine, a starter/generator is connected

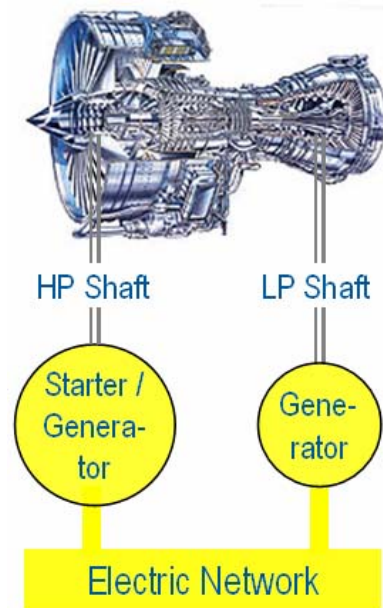

Fig. 3. A Potential Future Electric Power Supply System

to the high-pressure (HP) shaft of the engine. This is shown schematically in Fig. 3.

For a conventional aircraft architecture, each of the three power supply systems – electric, hydraulic and pneumatic – has to be sized for the peak demands of its consumers.

Usually, electrical systems tend to be heavier, but for a future all-electric aircraft only one power supply system has to be sized for the consumer peak demands. This can translate into a weight benefit compared to a conventional aircraft. To achieve the best possible weight benefit, methods are developed to minimise the design power of the electric generators (refer to chapter 2). Applying these methods in the design of the electric power supply system will help to achieve the smallest possible overall system weight. This is due to the fact that minimised generator design power also makes it possible to minimise the sizes of the electrical network components such as converters, power distribution centres, contactors, circuit breakers and wiring.

## 2 Generator Design Power Minimisation

### 2.1 Modifications to the Electric Power Supply System

Two measures are considered to achieve the smallest possible generator design power for an all-electric aircraft.

One way is to optimise the allocation of the numerous electrical consumers to the generators, to make the best use of the generator capabilities. The best use is made of the generators if their load profiles are as flat as possible throughout a flight cycle, without any significant peaks. Due to the diverse characteristics of the electrical consumers having different power needs during a flight cycle, it is possible to find an optimum combination of the electrical consumers to be connected together to a generator. The optimum combinations of the consumers will eventually lead to the lowest generator design loads. In shifting the connections of the electrical consumers to the generators, specific constraints, due to the redundancy required and residual power to be supplied following the possible failure of a generator or engine, have to be observed.

To illustrate the basic procedure, Fig. 4 depicts the power profiles of two single consumers. Then, Fig. 5 shows the summed power profile (both figures are equally scaled). Ideally, consumers are combined, the individual peak demands of which occur at separate times and ramps are running conversely. Due to cancel-

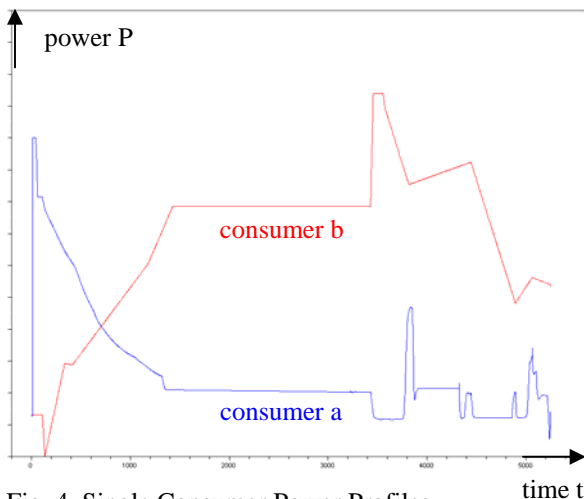

Fig. 4. Single Consumer Power Profiles

lation effects, this leads to a smoother summed profile, the peak power of which is not much higher than the peak of each single consumer profile. That way, adding more consumers to a generator does not or only minimally increase its design power.

Another way to minimise the generator design power is to temporarily reduce the power of some non-essential consumers, e.g. the environmental control system (ECS) and the galleys. In the case of a full-electric aircraft, the ECS will be a very large electrical consumer. A time-limited power reduction or shutdown of the ECS will not have an immediately noticeable effect on the occupants, merely a slow and marginal increase of the cabin temperature may appear. Furthermore, it is a normal operation procedure for today's pneumatically powered ECS to shut it down temporarily during engine start or take-off.

Another consumer worth considering is the galleys. Like the ECS, this consumer is relatively large. The galleys are not incessantly operated, but a power budget is reserved for possible use. This power budget needs to be higher during climb and cruise, since the warming up of the meals is usually done during these flight phases. A reduction of the galleys power budget during these flight phases can relieve generator design power, however, in doing so it could have a noticeable effect on the occupants. This may be studied in a trade-off between the electrical power budgets and the effect on the occupants.

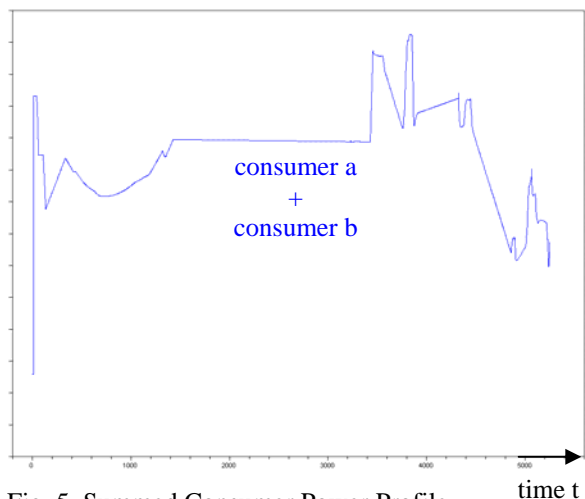

Fig. 5. Summed Consumer Power Profile

An intermittent power reduction or shutdown of some consumers requires the aircraft electrical power system to be equipped with dynamic load sensing and management. For the purpose of this paper, it is assumed that such equipment will be installed and credit can be taken for its function.

Basically, two measures to reduce and minimise the generator design power are now identified. Each measure on its own, a) optimising the consumer allocation and b) intermittent power reduction or shutdown of the ECS and the galleys, has some effect on the generator design power. The combination of both measures, however, leads to a more significant reduction in generator design power.

## 2.2 Generator Capability

The generator design power is determined by the highest and concurrent steady-state demands of all the electrical consumers supplied by a generator. Relatively short peak demands, e.g. due to landing gear retraction or high lift system operation, may be covered by the overload capability of the generators. Overload capability is a typical property of electrical generators. Simply speaking, it means that the shorter the duration of a power demand is, the higher it is allowed to be without having to increase the generator design power and size. This is illustrated by the following Fig. 6.

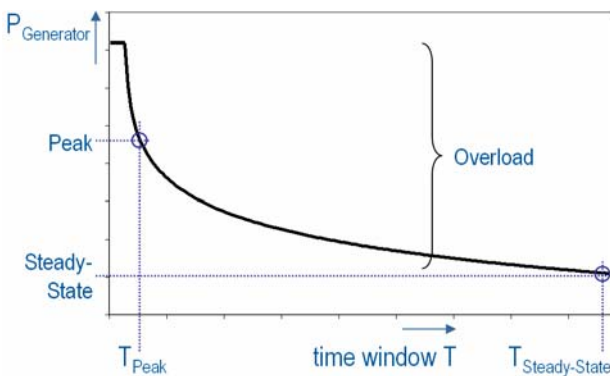

Fig. 6. Generator Capability

The generator capability  $P_{Generator}$  is displayed

versus the duration  $T$  of a “filtering time window”. This time window is defined to calculate filtered averages of the power profile supplied by a generator. A more precise definition and additional examples can be found in the next chapter.

## 2.3 Steady-State and Peak Power Definition

Throughout a flight cycle, a generator has to supply a varying power profile, sometimes with considerable peaks. These have to be analysed carefully, in order not to unintentionally increase the generator size for high but very short peaks. A peak must persist for a minimum duration to affect the generator design (refer to chapter 2.2).

Therefore, it is useful to introduce a filtered power characteristic that is computed from the original power profile  $P$  as

$$P_{filtered}(t, T) := \frac{1}{T} \int_{t-T}^t P(\tau) d\tau \quad (1)$$

for  $t \in [t_0 + T, t_e]$  and a fixed  $T \in (0, t_e - t_0]$ .

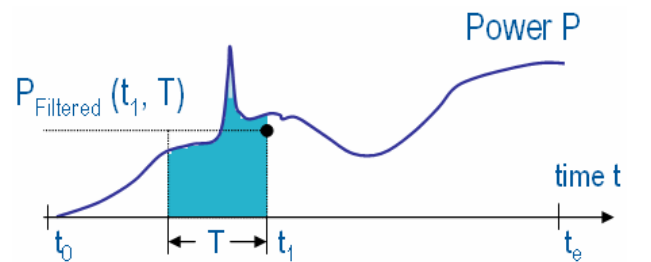

Fig. 7. Definition of Filtered Power

For every time instant,  $P_{filtered}(t, T)$  is computed as the integral average of the power  $P$  by application of the “continuously moving average” filter [1], which has the duration  $T$ . By selecting a specific  $T$ , different filtered power profiles can be produced. A larger  $T$  corresponds to the long-term behaviour, whereas a smaller  $T$  is associated with the momentary power behaviour (refer to Fig. 6).

It is appropriate to introduce  $T_{Steady-State}$  and  $T_{Peak}$  (also see Fig. 6), with  $T_{Steady-State} > T_{Peak}$  and to define

$$P_{Steady-State} := \max_{t \in [t_0 + T_{Steady-State}, t_e]} P_{filtered}(t, T_{Steady-State}) \quad (2)$$

$$P_{Peak} := \max_{t \in [t_0 + T_{Peak}, t_e]} P_{filtered}(t, T_{Peak}) \quad (3)$$

The values of  $T_{Steady-State}$  and  $T_{Peak}$  have to be selected according to the design rules specific to a generator. Here, the following values are chosen exemplarily, in order to reflect common typical generator characteristics:

$$T_{Steady-State} = 5 \text{ min}; \quad T_{Peak} = 5 \text{ s}$$

To illustrate the above definitions, Fig. 8 and Fig. 9 show an identical example power profile  $P$ . From the profile  $P$ , the respective  $P_{filtered}$  (1) profiles,  $P_{Steady-State}$  and  $P_{Peak}$  are derived. The maximum values, as defined by (2) and (3), are available at the time instant  $t = t_e$ .  $P_{Steady-State}$  is also denoted as the generator design power. Due to its overload capability, the generator can cover the consumer short-time demands up to

$$P_{Peak} \leq k \cdot P_{Steady-State} \quad (4)$$

For the selected  $T_{Steady-State}$  and  $T_{Peak}$  values, the generator overload factor  $k$  is typically in the range from 1.2 to 1.5. Again, this is an example which reflects common generator properties.

The described method of calculating filtered power profiles  $P_{filtered}$  can also be employed to establish a generator capability curve (qualitatively shown in Fig. 6), which then serves as a specification for the dimensioning of the generator. To do so, the power profile  $P$  including worst case scenarios must be available. Next, the profile  $P$  has to be filtered with a sufficient number of different time windows  $T$ , e.g. {5 min, 4 min, ..., 1 min, 30 s, 15 s, 10 s, 5 s} or finer. At last, the maximum of each filtered profile, as defined by (2) and (3), is taken to establish a curve of the required generator capability.

On this basis, a generator can be dimensioned to meet exactly the needs of the application, rather than assuming the generator characteristics a priori, and then checking that the consumer demands can be covered by the generator capability. The generator layout, the technologies applied and other its features can be tailored to the specific application. Hence, this method helps to avoid an over-dimensioning of the generator.

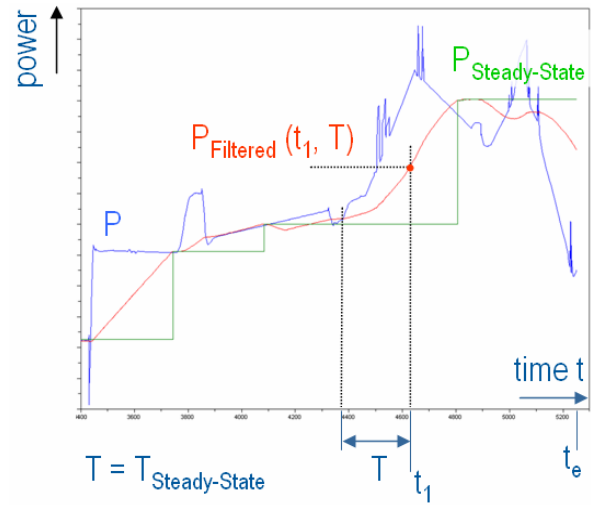

Fig. 8. Steady-State Power – Example

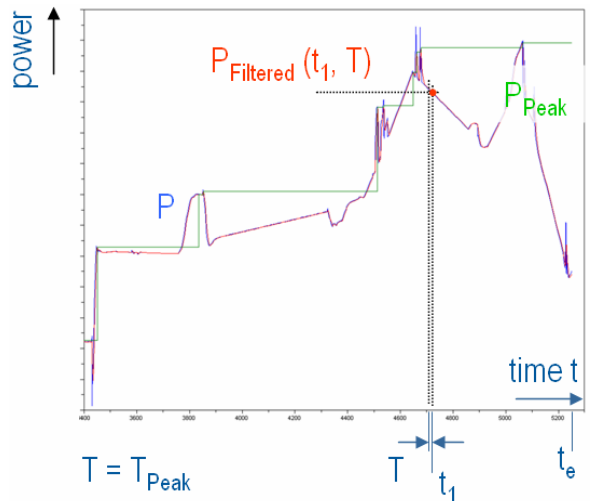

Fig. 9. Peak Power – Example

In the study described the generator power profiles, as well as the filtered profiles and the maximum values, are computed by simulations of an aircraft systems model. This aircraft systems model comprises the behaviour of the numerous power demanding components, which is further illustrated by chapter 3.1.

### 3 Optimisation Method and Software Tools

#### 3.1 The Virtual Iron Bird as a Modelling and Simulation Tool

Within the frame of the POA project, a Virtual Iron Bird (VIB) is created as a modelling, simulation and analysis tool to evaluate more-electric aircraft system configurations [2]. The focus is on analysing the power behaviour of the aircraft systems, the resulting non-propulsive engine off-takes and related fuel consumption at aircraft level. The VIB is configured as a hierarchically structured and object-oriented model library by use of the modern multi-physical modelling tool Modelica [3]. Tailored models of all components relevant for the power generation, distribution and consumption on an aircraft are developed and contained in the VIB model library.

The multi-physical modelling tool Modelica is selected for the VIB, particularly with regard to the complexity of aircraft systems, such as air conditioning and pressurisation, electric power generation and distribution, flight controls, hydraulics, landing gears etc., and the need to simulate all aircraft systems using different forms of power in one integrated model.

Modelica is a free modelling language with a textual definition to describe physical systems by differential, algebraic and discrete equations. It is designed to allow object-oriented modelling of complex physical systems, containing mechanical, electrical, hydraulic and thermal phenomena, as well as control or process-oriented effects. For simulation of the models written in Modelica the commercial tool Dymola [4] is used, which offers a graphical modelling editor and a translator for efficient code generation.

The Modelica-based VIB consists of several levels. On the top level, the model library contains a variety of aircraft system architecture configurations. Beneath the architecture level, models of the electrical power system, the flight control system etc. are gathered on the systems level. The system level models in turn are composed of generator, wire, motor, pump, cylinder etc. models that are part of the component level of the library. The assembly of different aircraft architecture models is realised in a flexible way by exchanging the accordant models from the lower levels of the library. An example of the hierarchical structure is given in Fig. 10, showing the electrical power system extracted from the aircraft architecture model and indicating one of the generators on the component level.

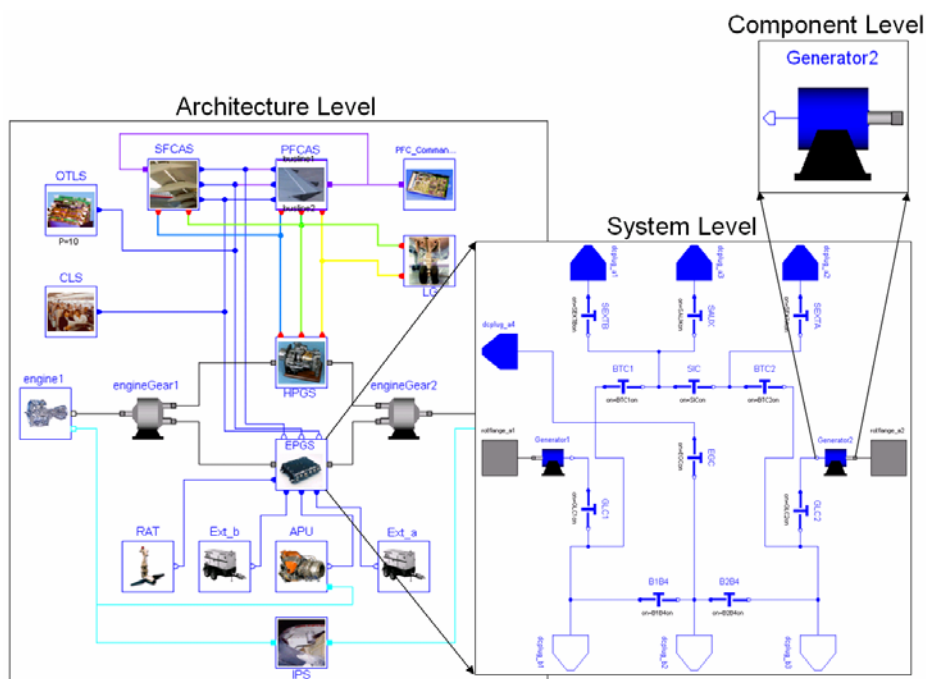

Fig. 10. Modelica Diagrams of Hierarchical Aircraft System Models on the VIB

Further details on the VIB model library, its structure and the modelling technique applied can be found in the reference [2].

Concluding this chapter, the VIB offers the capability to evaluate entire aircraft level architectures including all systems. A variety of aircraft system architecture candidates is built, evaluated and compared on the VIB. Due to its flexibility, the VIB is also used for the optimisation of aircraft system architectures, which is illustrated by the next chapters.

### 3.2 Optimisation Process

First, this chapter describes the pieces brought together to optimise, i.e. to minimise the generator design power. Next, it explains how the pieces are used in the optimisation process.

Simulations of aircraft system architecture models are performed on the VIB. Input to the simulations is a predefined flight profile, which controls the aircraft path and all related on-board system and consumer activities. A single flight profile is used in this study, in order to ensure comparability when simulating or optimising different aircraft architectures. The electrical power delivered by the generators is yielded as a simulation output. The filtered power profiles, as defined in chapter 2.3, are computed in the simulation as well. Thus the unfiltered generator power profiles over a flight cycle, as well as the

filtered steady-state and peak characteristics are available. The latter are used as criteria and constraints in the optimisation process. This is depicted in Fig. 11.

In the optimisation, the allocation of consumers to the generators, as well as an intermittent power reduction or shutdown of some non-essential consumers (refer to chapter 2.1) are the changeable variables, which are named tuners. Modifying the tuners is limited by the redundancy required for those consumers performing a safety critical function. These limitations are adopted as constraints.

An engineering evaluation of the criteria and constraints is done during the optimisation process, as shown by Fig. 11. This includes the following:

The necessary design power for the generators, which is needed to cover the steady-state demands, is read from the criteria. Additionally, the ratio of the steady-state and peak power is calculated for each generator to check that its overload capability is used but not exceeded.

The amount of energy reduced from the nominal consumer profiles is assessed in relation to the thus enabled decrease of generator design power. An intermittent consumer power reduction (refer to chapter 2.1) is equivalent to an amount of energy not being supplied by the generators. Such can translate into a drawback

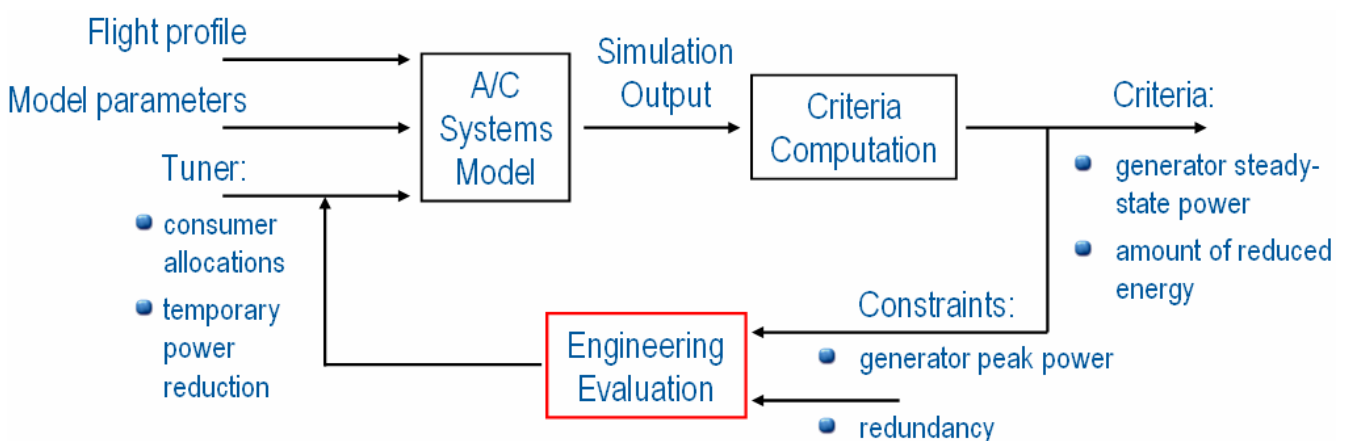

Fig. 11. Optimisation Process – Manually Solved

in consumer system performance, e.g. for the galleys and ECS. Consequently, a power reduction is done only during those flight phases when it is most effective for reducing generator design power, so that the amount of energy reduced (see Fig. 12) is as low as possible.

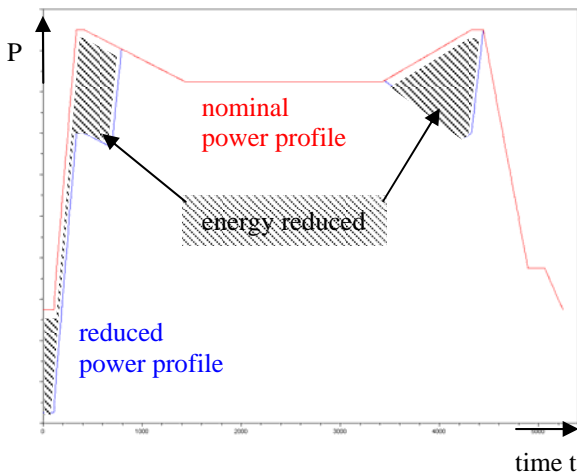

Fig. 12. Intermittent Consumer Power Reduction

Completing this engineering evaluation, the tuners are modified for a new run of the optimisation loop. The consumer power reduction schemes are adapted manually, as well as the shifting of the consumer allocations to the generators, which includes observing the constraints imposed by the redundancies required.

Repeated runs of the optimisation loop will produce a number of architecture variants. The best ones are certainly those with the smallest generator design power, achieved by the least amount of reduced energy. The best variants are selected by engineering evaluation, as described.

The optimisation loop is terminated when tuner modifications do not lead to a further decrease in generator design power, or when the lower limit of the overall generator design power is reached. The lower limit is established as the summed power demands of all electrical consumers during the cruise phase. Since this flight phase can run for a long time, enough generated power should be available to operate all consumers, including the ECS and galleys, at the

nominal rating for the cruise phase. Therefore, the overall generator design power, i.e. the sum for all engine driven generators on-board, should not be lower than this limit.

This chapter described how the task of minimising generator design power is solved by manually changing the tuners, i.e. the system configuration. The next chapter will describe a way to implement the optimisation problem for an automated dissolving.

### 3.3 Automated Optimisation

The manually performed optimisation reveals that the aim for generator power minimisation has a complex cross-linking to the criteria and constraints of the case study (refer to Fig. 11 and chapter 3.2). A manual dissolving of the optimisation problem is possible, as long as the number of different system configurations, tuners and constraints remains manageable. For example, the described case study includes four criteria ( $P_{Steady-State}$  for four generators), which are partially competing. If criteria are competing, this means that one criterion can be improved only at the expense of the other.

The optimisation task becomes difficult to survey when more tuners, criteria or constraints are introduced, and when some of these are competing. Thus, it is advantageous to develop an automated procedure for the dissolving of the optimisation problem, see Fig. 13.

A first step towards an automated optimisation is to define and classify tuners, constraints and criteria for the electrical power system design.

The independent variables – the tuners – can be divided into two classes: continuous and discrete tuners. Continuous variables are values that can vary within a certain range such as the amount of intermittent ECS energy reduction. In contrast, discrete tuners can only be selected from a countable number of possible values, mostly from  $\{0, 1\}$ . For each electrical consumer the two different tuner values 0 and 1 can



be interpreted as connection information to the LP- or the HP-generator.

The criteria to be minimised are described in the previous chapter 3.2, because they have to be computed for the manual optimisation process, too. In automatic optimisation, special care has to be taken for the constraint formulation. Several constraints are necessary to prevent the optimisation algorithm from selecting an optimal solution (in the sense of the criteria) which is technically unreasonable. In principle, constraints are described using equations and inequations, for example inequality (4) to guarantee that the generator overload capability is not violated.

In the second step towards an automated optimisation one has to apply an optimisation algorithm to solve the optimisation problem. Both continuous tuners for temporary power reduction and discrete tuners for consumer allocation have to be commonly varied to reach an optimal solution which fulfils the design constraints. Standard optimisation algorithms, like derivative based methods for continuous optimisation problems, cannot be applied to this hybrid problem class. The outstanding problem structure requires special optimisation algorithms, e.g. genetic algorithms which can treat continuous and discrete tuners. The genetic algorithm search method is based on evolution principles

from biology which guarantee the survival of the fittest individuals.

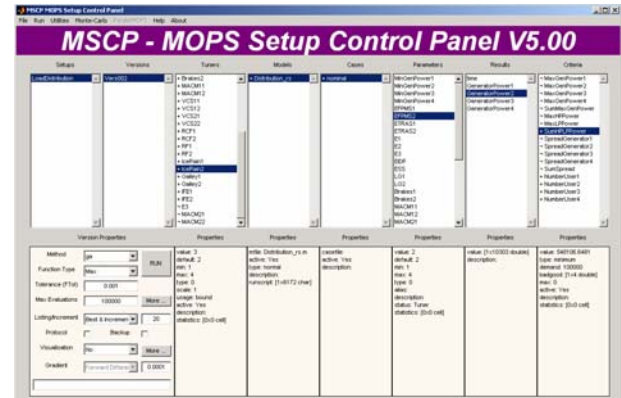

Fig. 14. MOPS-GUI for Electrical Power System Design Optimisation

Such algorithms are available in the Matlab tool MOPS (Multi-Objective Parameter Synthesis) [5]. It is a parametric assessment and optimisation tool with a graphical user interface (GUI, see Fig. 14) for convenient problem formulation and result inspection. MOPS has an interface to the Virtual Iron Bird (see chapter 3.1) which serves for the aircraft system simulation. In each optimisation iteration the simulation is evaluated for a different set of tuner values which result in corresponding criteria and constraint figures, see Fig. 13. The iteration is done as long as better designs can be found.

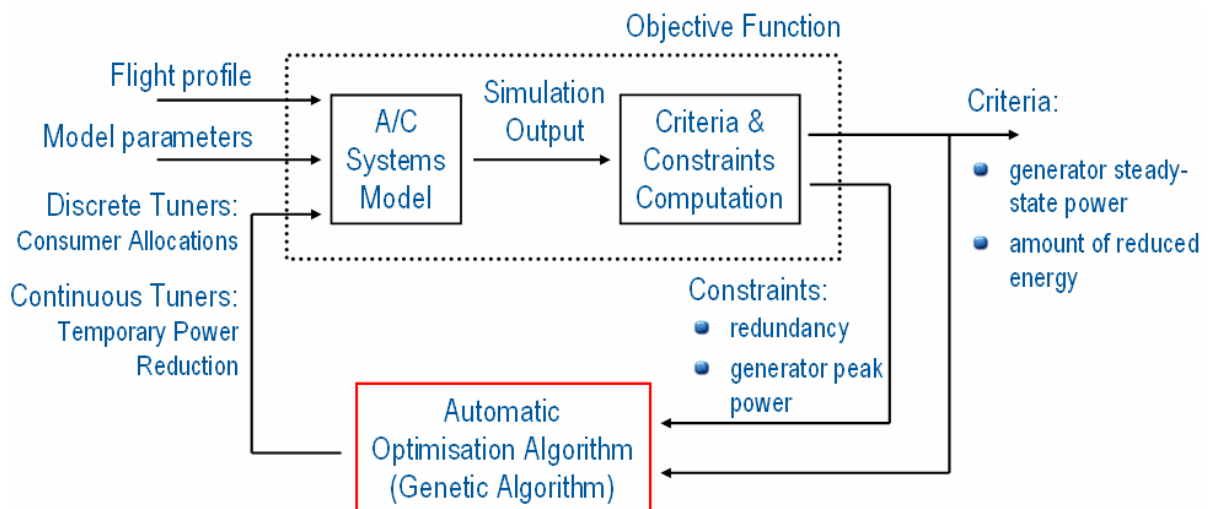

Fig. 13. Optimisation Process – Automatically Solved

At first sight the formulation and implementation of an electrical power system design problem need some effort, but the advantage of the automated optimisation approach is the feasibility to extend and refine the design problem without losing the overview of coupled design goals and requirements. This increasing complexity can be managed by software based automatic optimisation which shows the potential of the tool for future design work.

#### 4 Summary

This paper presented the methods developed for the minimisation of the generator power to be installed on a future all-electric aircraft. Minimising the installed generator power is a means to save weight on the generators, converters, feeder wires, busbars, contactors and the other miscellaneous equipment of the electric power supply system.

The generator power is minimised by optimising the allocation of the electrical consumers to the generators, in combination with an intermittent power decrease or shutdown of some non-essential consumers, e.g. the environmental control system and the galleys. The generators are sized for the maximum steady-state power demands, which are determined from the generator power profiles by a continuous average filtering technique. Advantage is taken of the generator overload capability for the coverage of short peak demands.

A Virtual Iron Bird (VIB) is configured as a modelling, simulation and analysis tool to evaluate the power behaviour of entire aircraft system configurations. The VIB model library is based on the object-oriented and multi-physical modelling tool Modelica. This tool supports a flexible assembly and alteration of complex aircraft architecture models, and also the simulation of all aircraft systems using different forms of power in one comprehensive model.

The complexity of the task of minimising the generator design power is demonstrated by a

manually executed optimisation. The process is centred to an engineering evaluation, which includes a rating of the steady-state and peak generator power that are computed by simulations of VIB aircraft system models, and a modification of the tuners by hand in consideration of the redundancy constraints.

Moreover, an automated optimisation procedure is developed. The intention is to overcome the limitations of the manually executed process, which may become time-consuming or even unmanageable when the number of tuners, criteria, constraints or architecture variants is increased. This procedure draws upon an automatic optimisation algorithm, which performs an evaluation of the criteria and a modification of the tuners in lieu of the engineer. The design rules, i.e. the criteria and constraints, have to be mathematically formulated, so that the optimisation algorithm can automatically find practicable solutions. This automated approach is supported by the Matlab-based optimisation tool Multi-Objective Parameter Synthesis (MOPS). The interface of this tool with the Modelica-based VIB thus enables a complete integration of the automatic optimisation process. This demonstrates the potentials of integrated modelling, simulation and optimisation tools for future aircraft systems design.

#### References

- [1] Faleiro L F. Power Optimised Aircraft – The Future of Aircraft Systems. *AIAA/ICAS International Air and Space Symposium and Exposition: The Next 100 years*, 2003.
- [2] Bals J, Hofer G, Pfeiffer A and Schallert C. Virtual Iron Bird - A Multidisciplinary Modelling and Simulation Platform for new Aircraft System Architectures. *Deutscher Luft- und Raumfahrtkongress 2005*, Friedrichshafen, DGLR-JT2005-243, September 26-29 2005.
- [3] Modelica Language: [www.modelica.org](http://www.modelica.org)
- [4] Dynasim Dymola: [www.dynasim.se](http://www.dynasim.se)
- [5] Joos H-D, Bals J, Looye G, Schnepfer K and Varga A. A multi-objective optimisation-based software environment for control systems design. *IEEE International Conference on Control Applications and International Symposium on Computer Aided Control Systems Design*, Glasgow, Scotland, UK, September 18-20, 2002, Proc. of CCA/CACSD 2002, P. 7-14, 2002.