

# TRANSFORMING THE NAS: THE NEXT GENERATION AIR TRAFFIC CONTROL SYSTEM

**Heinz Erzberger**  
**NASA Ames Research Center**  
**Moffett Field, CA 94035**

**Keywords:** *Air traffic control, automation, air traffic management, aircraft operations*

## **Abstract**

*The next-generation air-traffic control system will have to be able to handle, safely and efficiently, a traffic density that will be two or three times that accommodated by the present system. Capacity of the en route and transition (arrival/departure) airspace of the present system is principally limited by the controller workload associated with monitoring and controlling aircraft separation. Therefore, the key to achieving a large increase in the capacity of this airspace is a reduction in controller workload, which can be accomplished by automating the monitoring and control of separation and by using an air-ground data link to send trajectories directly between ground-based and airborne computers. In the proposed next-generation system design, the Advanced Airspace Concept (AAC), computer logic on the ground monitors aircraft separations and uplinks modified trajectories when potential conflicts between aircraft develop. During flight, pilots can downlink requests for trajectory changes to the ground system; their requests are revised by the ground system only as necessary to eliminate possible conflicts and to comply with other control system restrictions. If adapted to approach control, the system could increase landing rates by 25%. An AAC system architecture, consisting of software and hardware components on the ground and onboard aircraft, is defined. A separation-assurance system, which activates in the event of a failure in the primary ground-based system, is an essential element of the AAC. It is recommended that there be a phased transition from the present air-traffic control system to the AAC in order to minimize risks and to begin*

*realizing the benefits of the AAC as soon as possible. Results from a safety analysis indicate the potential for the system to reduce the collision risk substantially compared to that of the current system.*

## **1 Introduction**

The next-generation air traffic control system must be designed to safely and efficiently accommodate the large growth of traffic expected in the near future. It should be sufficiently scalable to contend with the factor of 2 or more increase in demand expected by the year 2020. Analysis has shown that the current method of controlling air traffic cannot be scaled up to provide such levels of capacity.

The capacity of en route airspace, if constrained only by legally required separation criteria, has been shown in a preliminary study [1] to be several times greater than the capacity achieved by the current method of control. Controller workload associated with monitoring and controlling separation is known to be the primary constraint that limits the capacity of an airspace sector. The maximum number of aircraft a controller can safely monitor in a sector is approximately 15. Until recently, the strategy for gaining capacity without exceeding this limit has been to subdivide and redesign sectors. However, that strategy has reached the point of diminishing returns in high-density traffic regions such as the Northeast Corridor of the United States. It is not practical, for example, to reduce the size of a sector below the minimum size a controller needs in which to maneuver aircraft. Furthermore, reducing sector size also increases the controller's intersector

coordination workload, which diminishes the benefits of reducing sector size. Another approach to increasing airspace capacity is to provide controllers with decision support tools. Although such tools may offer small gains they fall far short of being able to double the capacity.

Therefore, to achieve a large increase in capacity while also giving pilots increased freedom to optimize their flight trajectories requires a fundamental change in the way air traffic is controlled. The key to achieving a factor of 2 or more increase in airspace capacity is to automate separation monitoring and control and to use an air-ground data link to send trajectories and clearances directly between ground-based and airborne systems. In addition to increasing capacity and offering greater flexibility in the selection of trajectories, this approach also has the potential to increase safety by reducing controller and pilot errors that occur in routine monitoring and voice communication tasks.

Pilots of appropriately equipped aircraft operating in airspace under control of this new system will have greatly increased freedom to downlink trajectory change requests to the ground system. Aircraft in the sector will be able to request and receive trajectory changes concurrently, since the ground-based computer logic ensures that all uplinked trajectories will be mutually conflict-free. Relieved of routine monitoring and control tasks, controllers will be able to devote more time to solving strategic control problems, managing traffic flows during changing weather conditions and handling other unusual events. Controllers will still assume separation assurance responsibilities for an aircraft in the event it loses its data link or requires manual handling as a result of on-board system failures. In addition to the redundant fail-safe separation-assurance logic on the ground, aircraft will be further protected against collisions by the on-board traffic alert and collision avoidance system (TCAS), as they are today.

A candidate system, the Advanced Airspace Concept (AAC) [2-3], which is intended to meet the performance requirements

described above, has been under study at NASA Ames Research Center. Although the AAC makes fundamental changes in the roles and responsibilities of controllers, it also retains the ground system as the core of the air traffic control process. Moreover, its ground-based elements are compatible with and are complementary to the FAA's planned modernization of the ground-system infrastructure.

The AAC can also be viewed as a platform for transforming controller-dependent decision support tools designed for the current operational paradigm into autonomous (controller-independent) control processes. Without the constraints imposed by controller workload, the decision and control processes driving these tools can be optimized to achieve their full potential for increasing capacity and efficiency. Decision support tools for control of arrival traffic are important candidates for transformation into autonomous functions within the AAC platform.

The design of the AAC system, described in this paper for en route airspace, can also be adapted to terminal-area control. By combining automated separation assurance with uplinked approach trajectories for precise control of final approach spacing, it is expected that the runway landing rate can be increased by about 25% with current separation standards.

The FAA's current plan for upgrades to air traffic services does not include giving permission to the future ground system to issue separation-critical clearances or trajectory changes autonomously to aircraft via data link without explicit approval of a controller, as is proposed herein [4]. If further research can convincingly demonstrate the operational feasibility, safety, and performance benefits of the concept, the FAA and the air traffic users will have to decide if this capability should be included in the future air traffic service system and, if so, when it should be inaugurated.

A proposed architecture for the AAC, comprising software and hardware components on the ground and on board aircraft, and an initial concept of operations are described in this paper.

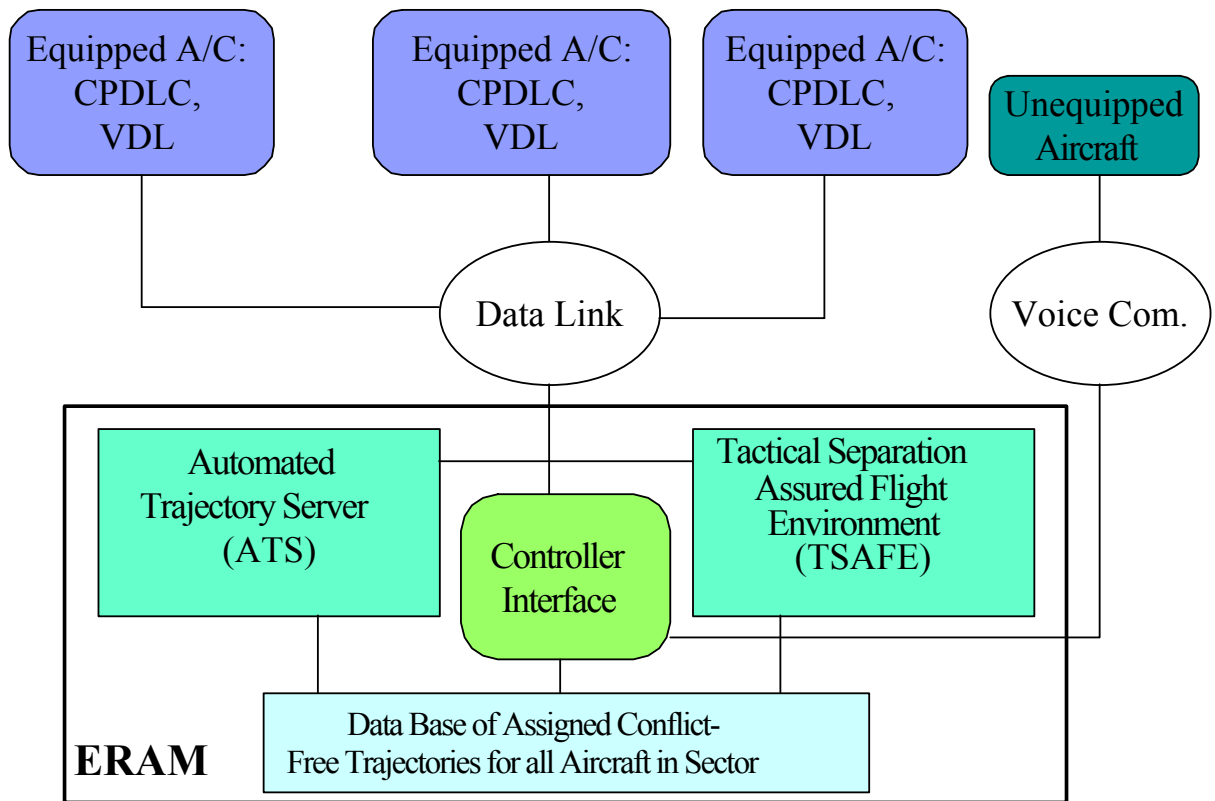

Fig.1 System Architecture of AAC

## 2 Architecture and Elements of Advanced Airspace Concept

Fig. 1 shows the major elements of the AAC and the information flow between elements. The elements consist of the following:

- Aircraft equipped with data link receivers/transmitters such as VDL (VHF data link version 2 or higher), Controller Pilot Data Link Communications system (CPDLC) and associated interfaces that permit pilots to send to and receive from ground-based computers trajectories and other air traffic control (ATC) messages. Unequipped aircraft are defined as those without a data link.
- Data link receivers/transmitters on the ground for exchanging trajectories between ground computers and equipped aircraft. An Automated Trajectory Server (ATS) on the ground for analyzing downlinked trajectories and

generating conflict-free trajectories for uplinking to equipped aircraft.

- A backup system for short term detection and resolution of conflicts referred to as the Tactical Separation Assured Flight Environment (TSAFE)
- An up-to-date database of currently assigned conflict-free trajectories and flight plans for all aircraft in the sector.
- A controller display and controller-computer interfaces with ATS, TSAFE and data link information.

It is assumed that the AAC ground-based elements would be incorporated into the Federal Aviation Administration's (FAA) planned replacement for the current host computer complex. This replacement system is known as En Route Automation Modernization (ERAM), which the FAA plans to deploy in about 2010. The VHF data link version 2 or 3 (VDL-2 or -3) has sufficient bandwidth to support initial AAC

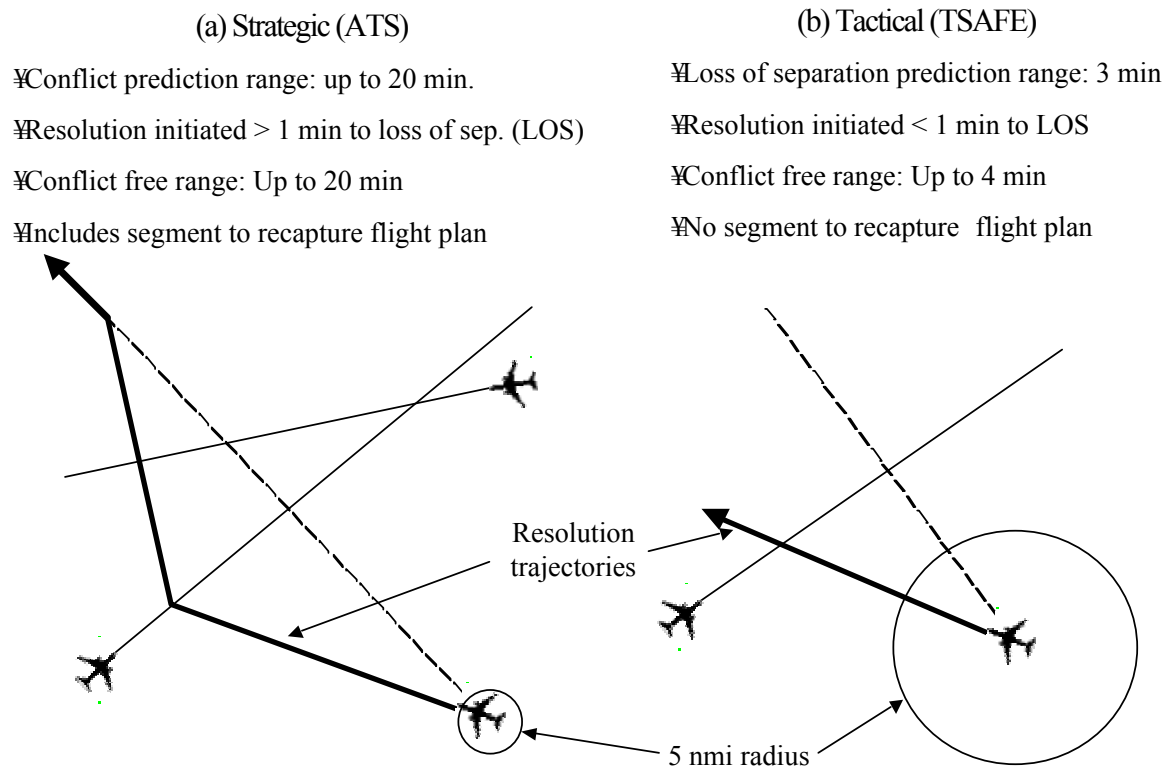

Fig. 2 Characteristics of tactical and strategic resolutions

operations. However, a priority message management system on the ground will be required to ensure that time-critical messages, such as near term conflict resolutions, are delivered to aircraft within a specified time period. In addition, a data link based on Mode S is assumed to be available as a low data rate, but high reliability, backup in the event of a VDL failure.

The message set developed for the Controller Pilot Data Link Communications (CPDLC) system [5] is sufficient for specifying and exchanging flight plans as well as three-dimensional trajectories between the ground and aircraft in an initial version of this concept. A standard voice link provides controller-pilot communications with unequipped aircraft; it can also be used to communicate with equipped aircraft when necessary.

### 3 Automated Trajectory Server

The ATS is the workhorse of the AAC and is also its most complex software element. It

generates trajectories that are conflict-free for up to 20 minutes, as measured from the current time. The ATS includes a conflict detection function, which periodically performs a conflict search of all aircraft operating in the airspace controlled by the system. The conflict detection search cycle is typically synchronized with the radar (or other available sensor) update cycle.

When this function detects a conflict (predicted loss of legally required separation) within about 20 minutes (but not less than 1 minute) from the current time, the ATS will attempt to generate a strategic resolution trajectory that is conflict-free and that also meets other traffic management constraints. Thus, a strategic resolution trajectory resolves the primary conflict; it is free of secondary conflicts, and includes a trajectory segment for recapturing the original flight plan at a downstream waypoint that is efficient for both the aircraft and ATC. The scenario shown in Fig. 2(a) gives an example of a strategic resolution trajectory. Although the resolution trajectories may extend a long distance down range, terminating at

waypoints near the destination airport, they are typically planned to be conflict-free for only the first 10-20 minutes, measured from the time instant they are generated. Because of the complexity of a particular traffic situation a new resolution trajectory may occasionally be conflict-free for as short as only 5 minutes. Such a short duration is close to the lower limit of acceptability, but it would occur infrequently. Once the resolution trajectory has been computed it is sent to the aircraft via data link. The next step in the process is for the pilot to downlink a "Will comply" message to the ground system, acknowledging that the trajectory has been received and that it will be executed as specified. If the pilot downlinks this message within the specified response time, the ATS ratifies the trajectory change process by updating the flight plan database. All the steps involved in replacing a trajectory should normally be completed in less than 2 minutes. However, a faster turnaround time would be required if loss of separation is less than 2 minutes away. In general the up-linked resolution trajectory will include an urgency indicator that will rise to the highest level as the time to loss of separation counts down to less than two minutes. (Fig. 2(b) is discussed later, in the TSAFE section.)

Flight crews can also access the ATS via their onboard data links and use it to revise their currently planned trajectories. For example, a pilot may want to change cruising altitude or the route of flight in order to avoid turbulence or to improve flight efficiency. The steps involved in this process are similar to the ATS-initiated conflict resolution situation. The ATS checks the pilot-requested trajectory for conflicts and violations of traffic management constraints. If no conflicts or violations are detected, the ATS sends a message to the aircraft approving the request. However, if the ATS does detect violations, it will generate a minimally modified replacement trajectory when possible. The pilot then has the option of accepting or rejecting the modified trajectory. He can also select and then downlink another trial trajectory. Thus, a series of trial requests by the pilot and responses by the ATS can ensue that terminate either when

the pilot accepts an ATS modified trajectory or when he rejects all options offered. If he rejects all options, he agrees to continue flying the original (unmodified) trajectory.

Finally, the controller also has access to the ATS using an interactive tool referred to as trial planner [6-7]. Situations can arise when a controller needs to plan new trajectories for an individual aircraft or for a set of aircraft. For example, the controller may wish to replan the flow of traffic around a weather system or issue clearances via voice link to aircraft that have lost their data link. Since both pilots and controllers can independently and concurrently engage in interactive sessions with the ATS, it is essential for the maintenance of a conflict-free environment that the controller submit all trajectory change requests to the ATS through the trial planner tool. Using this tool, controller-initiated trajectory changes are handled in the same way as ATS or pilot-initiated changes. ATS evaluates the controller-requested changes for conflicts and traffic management constraints. When all constraints have been met, the controller can direct the ATS to uplink the changed trajectories to the subject aircraft. Finally, after the pilot has downlinked a "Will comply" message, the ATS will update the flight plan database with the new trajectory and signal to the controller that this action has taken place.

The key to the operational integrity of this concept is for the ATS to ensure that the trajectories stored in the flight plan database are always up to date and that they remain free of conflicts and other constraint violations for some minimum time interval. An interval of 5 minutes, starting at the current time, establishes the lower bound, with 10 minutes being a more typical interval. The safety of operations under this concept depends on the ATS continuously monitoring the conflict status of all trajectories in the database and ensuring that resolution trajectories are uplinked well before any aircraft's conflict-free time-to-go has counted down to less than one minute before loss of separation (LOS). Of equal importance is the requirement that every trajectory change, whether initiated by the pilot or the controller,

not take effect until and unless the ATS has approved the change.

The trajectories provided by the ATS must solve the principal kinds of air traffic control problems encountered in different regions of the airspace. For example, the problems encountered in en route airspace differ from those encountered in arrival and departure airspace. Therefore, the task of building the ATS can be undertaken by dividing it into several subtasks. AAC operations will be limited to regions of airspace in which the problem solving ability of the ATS has reached a specified standard.

Work is in progress to specify the algorithms and to write the prototype software for generating the resolution trajectories required in en route airspace. This work builds upon an extensive set of algorithms and legacy software previously developed for the Conflict Probe and Direct-To tools [6-7]. These tools are integrated into the Center-TRACON Automation System (CTAS) [8].

A special subset of the ATS will provide trajectories required for control of arrival and departure traffic at high capacity hub airports. These kinds of trajectories are conceptually and algorithmically similar to those generated in decision support tools for controllers. The tools for these applications include (1) the En Route Descent Advisor (EDA) [9] for sequencing and spacing traffic to an arrival gate, (2) the Final Approach Spacing Tool (FAST) [10] for sequencing and spacing traffic to one or more runways, and (3) the Expedite Departure Planner (EDP) [11] for advising pilots on reaching cruise altitudes efficiently. These tools are also integrated into the CTAS software suite of decision support tools. Although these tools are designed to output advisories to controllers, the advisories themselves are actually derived from four-dimensional (4-D) trajectories that are conflict-free solutions to the traffic control problems defined above. Therefore, the 4-D trajectory generation software developed for these tools can be adapted for use in the ATS. Instead of controllers having to issue advisories that the tools obtain by simplifying the 4-D trajectories, the ATS will uplink the complete 4-

D trajectories, which flight crews can download into their onboard flight management computers. This approach enabled by the AAC should significantly increase flight efficiency, air traffic control performance and controller productivity.

#### 4 TSAFE

TSAFE (Tactical Separation Assured Flight Environment) plays the role of a backup system to the Automated Trajectory Server. If the ATS could be designed so that it would never fail to detect conflicts and to provide resolution trajectories in a timely manner, TSAFE would, of course, be unnecessary and therefore superfluous in the architecture of the AAC. There are, however, practical reasons why the ATS as a stand-alone system cannot be made reliable enough to guarantee that there will be no loss of proper separation. In its mature state the ATS software will most likely contain more than a million lines of code; for that software to be used as an autonomous agent in a safety-critical application, both its reliability and its operational limitations would have to be rigorously established. That process is not feasible for a code as large and complex as the ATS code. The approach taken here is to resolve this problem by inserting a redundant element, TSAFE, into the ground-based architecture. TSAFE thus duplicates a limited set of safety-critical functions of the ATS, and thereby comprises a design that trades off the ATS's complex functionality with its undeterminable reliability for a limited functionality with high reliability. Its code and algorithms will be structured to lend themselves to the rigorous verification and validation procedures required for certification of safety-critical applications.

As shown in Fig. 1, TSAFE operates in parallel with the ATS. Both receive surveillance data, and both can exchange data with aircraft via data link. However, because TSAFE's functionality focuses exclusively on preventing loss of separation for short-term predicted

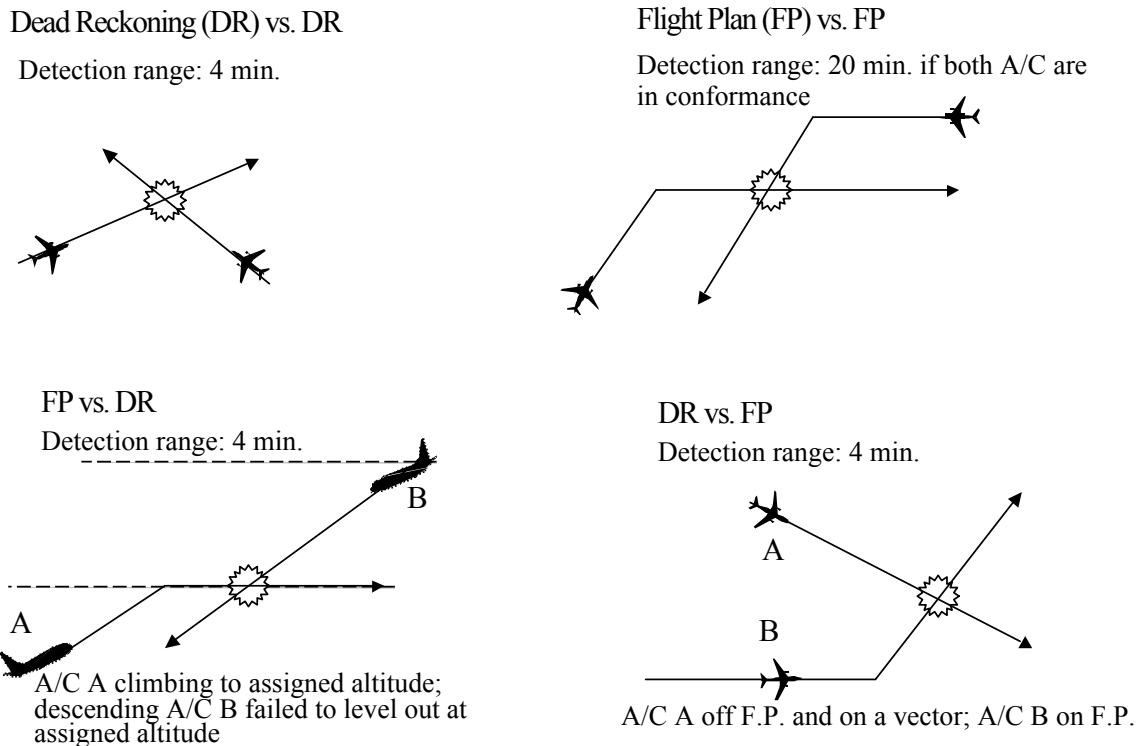

Fig. 3 Multi-trajectory conflict detection

conflicts, its software design will be far simpler than that of the ATS.

Like ATS, TSAFE contains both conflict detection and resolution functions. However, these functions are limited to a time horizon of only 3-4 minutes. The horizon for the detection function is similar to that of Conflict Alert, which has been in operation at air traffic control facilities for many years.

The conflict detection function in TSAFE uses a multi-trajectory analysis technique that can detect conflicts missed by Conflict Alert or by long-range conflict detection. In this technique two kinds of predicted trajectories are generated for each aircraft: dead reckoning (DR) and flight plan intent (FP) trajectories. Dead reckoning trajectories use an aircraft's current position and velocity to project its future location. They are similar to the types of trajectories used in Conflict Alert. Flight plan intent trajectories, on the other hand, are the basis for strategic, or long time-horizon, conflict probing. In addition to an aircraft's route of flight, FP trajectories use climb and

descent performance and atmospheric models to compute predicted 4-D trajectories. The methods used to compute FP trajectories for the Conflict Probe and Direct-To tools in CTAS are described in references 12 and 13. TSAFE uses both kinds of trajectories for each aircraft in searching for conflicts within a time horizon of 3 minutes. Thus, TSAFE searches for conflicts along the four pairs of trajectories formed by choosing the four combinations of dead reckoning and flight plan trajectories for each aircraft. The four pairs formed are therefore DR versus DR, FP versus FP, DR versus FP and FP versus DR trajectories. Each pair searched can result in a detected conflict. In order to avoid false alerts in the conflict detection process, DR trajectories are normally truncated at points where they extend past an assigned altitude toward which an aircraft is climbing/descending or past a waypoint where an aircraft will turn to capture a new route segment. An exception to the truncation rule is made for critical maneuvers conflicts, which are explained later in this section.

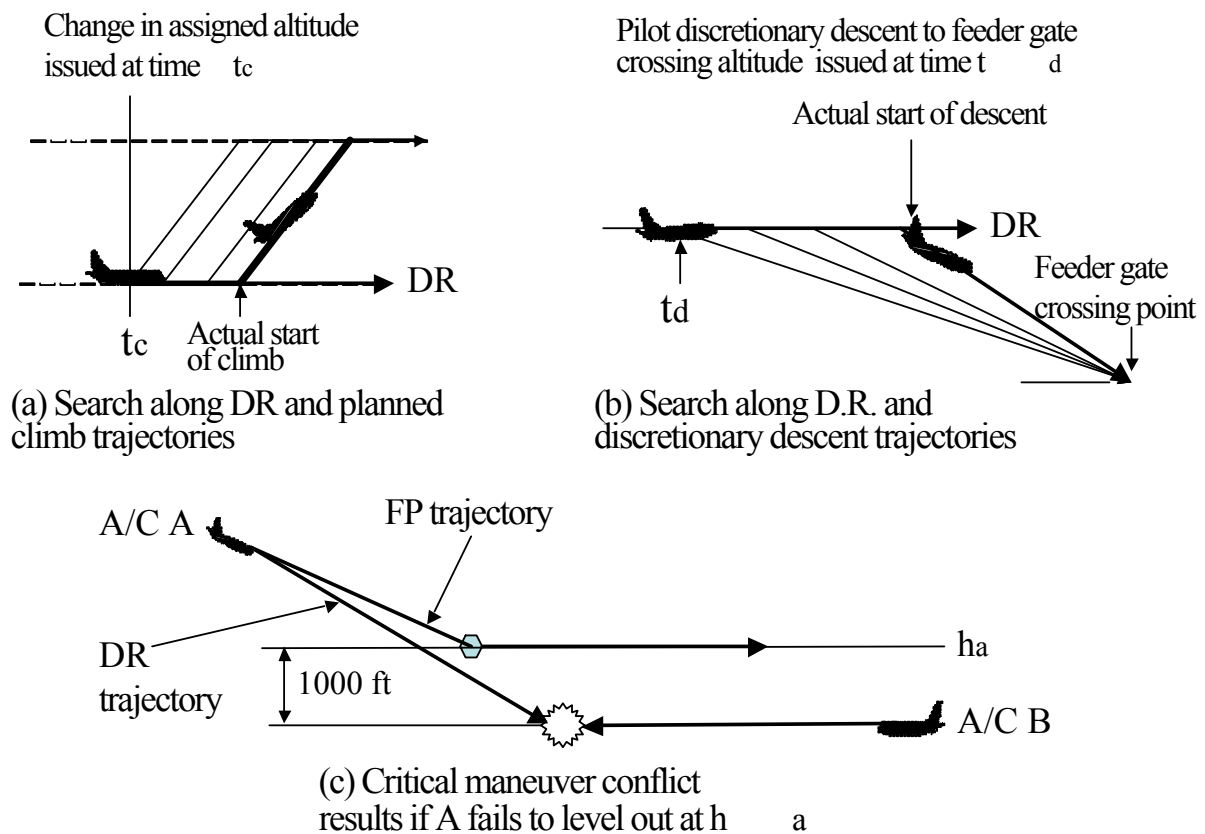

Fig. 4 Detecting conflicts during clearance execution

Fig. 3 illustrates the four combinations of trajectory pairs that can arise in this method. Playback of recorded air traffic tracking and flight plan data containing incidences of loss of separation has shown that the multi-trajectory search procedure provides more complete identification of potential conflicts than any single trajectory search procedure can. This approach was developed to help avoid the ambiguity that is often encountered in deciding which one of the two types of trajectories to use in the detection process. It avoids the inevitable compromise of having to select a single trajectory when either trajectory could reasonably occur. In effect, the multi-trajectory approach makes it possible to unify short and long-range detection seamlessly in a single system. Furthermore, the search along the pair of dissimilar trajectory types DR versus FP and FP versus DR used in the multi-trajectory method detects a class of conflicts found neither by Conflict Alert nor by conflict probing. The multi trajectory search is

especially effective in finding conflicts when aircraft are climbing or descending or when they are flying off their flight plan routes. The method can also provide an alert to an impending conflict that will occur as soon as an aircraft begins executing a recently issued flight plan or altitude amendment while continuing to search for and identify conflicts along the current flight direction.

Fig. 4 shows two examples in this category of conflict prediction. In Fig. 4(a), an aircraft has received a clearance to a newly assigned altitude at time  $t_c$ . However, the pilot's initiation time of the altitude change maneuver cannot be precisely predicted and can be delayed by several minutes. To account for this uncertainty both the DR and the predicted climb trajectories are used in conflict detection. The two trajectories are refreshed at every radar track update (about every 12 seconds). Although the difference between the two trajectories will diminish after the aircraft begins its climb, both trajectories are still



needed to protect against unexpected or unmodeled deviations from nominal climb profiles. For example, pilots will occasionally deviate from their standard climb or descent profiles when encountering turbulence.

The scenario shown in Fig. 4(b) illustrates the trajectory prediction problem after the pilot has been issued a discretionary descent clearance at time  $t_d$ . When issued this kind of descent clearance the pilot has the freedom to choose the top of the descent point and the descent profile but has to meet the constraint of crossing an arrival feeder fix at a specified position and altitude. As shown in the figure, the descent angle of the trajectory that is required to meet the feeder gate crossing restriction continues to change with position and does not freeze until the pilot initiates the descent. The start time of the descent can vary by up to 5 minutes and is unknown to TSAFE. Thus, the dual trajectory-detection method is especially important in this case.

In these and similar situations, the ambiguity in the predictive trajectories cannot be resolved until the start of the maneuver has been detected. If the search detects more than one conflict for an aircraft, the conflict pair with the earliest time to LOS is given priority. Although multi-trajectory conflict search is inherently susceptible to a higher false alert rate, false alerts have not been found to pose a significant problem over the short 3 min. time-horizon the method is used. The increased protection against missed conflicts achieved by this method is essential to ensure the safety of operations controlled by a highly automated ground system even at the cost of a somewhat higher false alert rate.

TSAFE also alerts to certain non-conflict situations referred to as critical maneuvers [2-3]. These situations identify precursor conditions that can lead rapidly to high-risk conflicts if an aircraft, which is currently executing a transition maneuver, such as changing altitude, does not terminate the maneuver when the termination state is reached; these situations can occur either in the horizontal or vertical plane and are referred to as critical maneuver conflicts. Fig. 4 (c)

illustrates the critical maneuver concept in the vertical plane. In the scenario shown, aircraft A is descending toward an assigned altitude,  $h_a$ . Aircraft B is flying level one flight level below A and is on a trajectory that would result in an immediate loss of separation if A should fail to level out when it reaches  $h_a$ . TSAFE computes a FP trajectory consisting of a descent segment to  $h_a$  that is followed by a level flight segment starting at  $h_a$ . TSAFE also computes a DR trajectory, which is allowed to extend to altitudes below  $h_a$  as the aircraft approaches the leveling-out altitude,  $h_a$ . If the DR trajectory of A extending below  $h_a$  yields a conflict with B, as shown in Fig. 4c, a critical maneuver conflict has been found. Alerts for critical maneuver conflicts can be shown to controllers on their displays or sent to pilots via data link to help ensure that transition maneuvers are completed accurately. Critical maneuver conflicts are given a separate classification since they are not actual predicted conflicts. Analysis and replay of actual LOS incidents in en route airspace shows that some of the severest conflicts were preceded by critical maneuver conflicts. These conflicts are often caused by communication errors between controllers and pilots. It is the genesis of these incidents and the desire to prevent them that led to the formulation of the critical maneuver concept. In addition to enhancing the safety of AAC operations, this new type of alert can be incorporated into Conflict Alert to enhance the safety of the current system.

Developmental software for TSAFE has been written and inserted into CTAS, allowing its performance to be evaluated using recorded or live input data. By replaying archived tracking data of actual cases of loss of separation in the software, it was found that TSAFE would have predicted the loss of separation earlier and with fewer missed alerts than Conflict Alert did under the same conditions. A report on this study is in preparation. The conflict detection methods in TSAFE could also be incorporated into the current system as a replacement for or enhancement of Conflict Alert.

The set of conflicts detected by the conflict detection function is sent to TSAFE's conflict resolution function. By design, the resolutions generated in TSAFE are conflict-free for only about 4 minutes from the current time. They not only have a short conflict-free time range but also are limited primarily to only two possible maneuvers: (1) climb or descend to a specified altitude; and (2) turn right or left to a specified heading. A third type, speed change, may be used for special situations such as in-trail overtake conflicts. These limited kinds of resolutions are defined as tactical, whereas those generated by the ATS were previously defined as strategic. Fig. 2(b) gives an example of a type 2 tactical resolution. As illustrated in the example, tactical resolutions are considered incomplete in that they lack a segment that returns the aircraft to the original flight plan. Tactical resolutions achieve the dual objective of avoiding imminent loss of separation while also providing a conflict-free time window of sufficient duration (4 minutes) during which the ATS can attempt to generate a strategic resolution. As long as the ATS remains operational (its software has not crashed) and is able to continue its search for a strategic resolution, the TSAFE resolution will be held in abeyance until the predicted time to LOS has counted down to a specified minimum time, which will likely be in the range of 1-2 minutes. Furthermore, TSAFE's tactical resolutions will be renewed periodically before they reach the end of their conflict-free time horizon, if ATS's strategic resolutions remain unavailable. It should be noted that the ATS must be made sufficiently robust so that TSAFE resolutions will occur infrequently.

A crucial design issue will be the specification of criteria for mode switching between ATS and TSAFE. Because TSAFE is the last defense against loss of separation in the AAC, the conditions for switching to TSAFE will have to be carefully defined.

As an element of a fail-operational system, TSAFE will run on independent computers and will not share software components with ATS, for which it is the

primary safety net. Its narrowly circumscribed functionalities and performance objectives are intended to yield a software design that is significantly less complex than that of the ATS. A code count on the order of 20,000 lines is estimated for TSAFE.

## 5 Pilot Procedures and Aircraft Equipage

Pilots flying appropriately equipped aircraft in AAC-enabled en route airspace will have substantially increased flexibility and opportunities to make changes in routing and assigned altitudes without having to request approval for such changes from controllers. As discussed in Section 3, pilots flying data-link-equipped aircraft in AAC airspace can connect into the ATS and trial-plan trajectory changes at any time. Although several pilots may be logged into the ATS simultaneously, they are guaranteed to receive mutually conflict-free trajectories. Since the controller is not an in-the-loop intermediary who receives and approves all change requests via voice communications, the number and frequency of change requests are not limited by controller workload as they are today.

For initial AAC operations the Controller-Pilot Data Link Communication (CPDLC) [5] system interfaced with Flight Management Computers is thought to provide sufficient onboard capabilities for exchanging trajectories with the ground system. Several airlines have begun to equip their aircraft with these systems. Therefore, it is an important attribute of the AAC that airlines and other airspace users will not have to install additional onboard equipment in order benefit from AAC services. However, the required ground-based elements, namely ATS and TSAFE, still have to be designed and developed.

The elimination of the controller workload bottleneck becomes especially important during periods of convective weather when many pilots may wish to modify their routes and altitudes almost at the same time in to order to avoid flying through rapidly moving convection cells. An example of such a

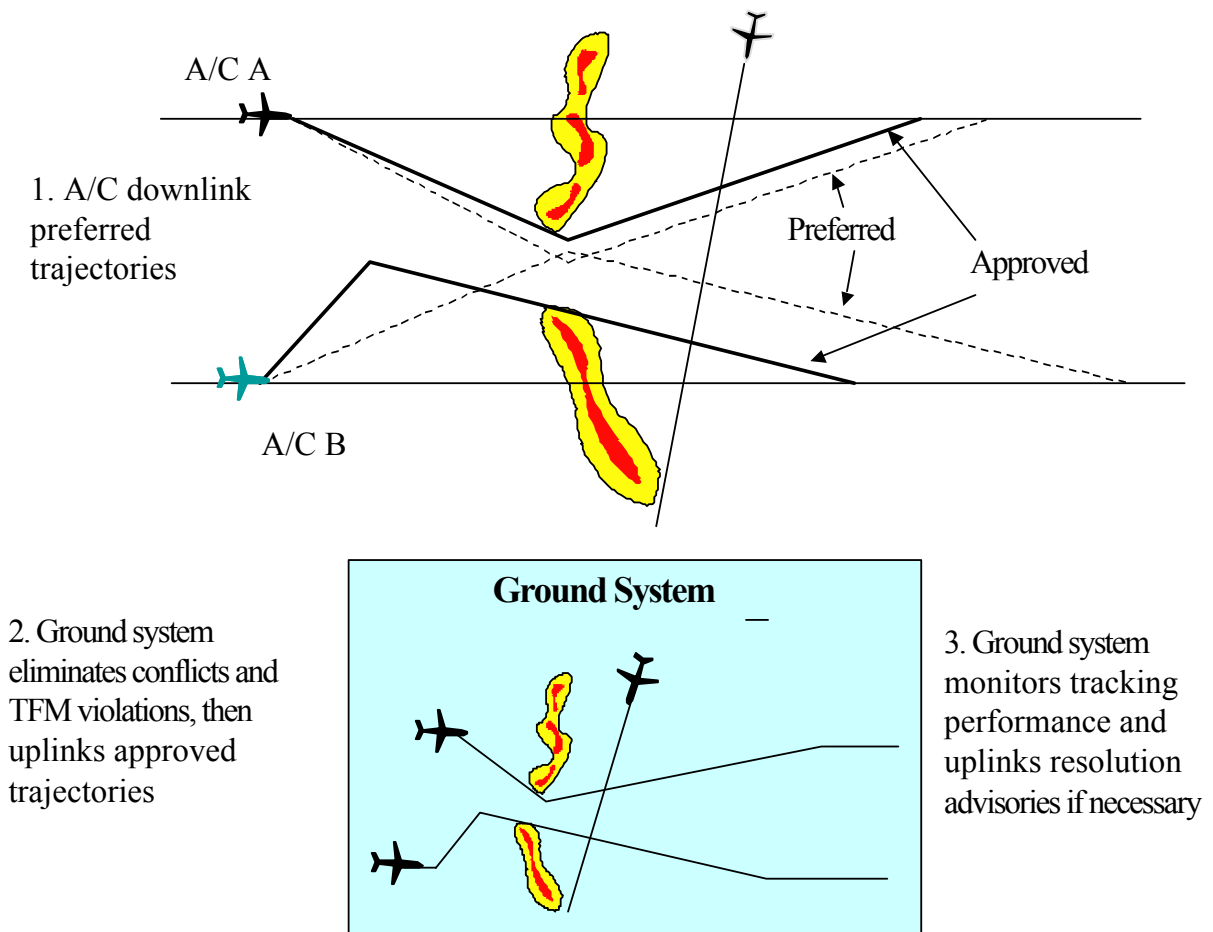

Fig. 5 En route procedures for AAC

situation is illustrated in Fig. 5, which shows traffic flying into a region of convective weather activity. The weather fronts shown are similar to those recorded a few years ago in the Eastern United States. When encountering such weather controllers may shut down a large block of airspace to all traffic in the area of the front, causing major air traffic delays. The combined north-south range of these fronts is about 400 miles. In the situation illustrated, the pilots of the two aircraft heading for these fronts have both logged into the ATS to plan changes in routes in order to avoid flying through the heaviest convection areas. Both pilots have downlinked their requests for new routes, shown as dashed lines, that take them through the narrow region between the two fronts at nearly the same time. The trajectory analysis engine in the ATS finds the two requested routes in conflict with each other as

well as with that of a third aircraft east of the weather front. The ATS changes the requested routes just enough to eliminate the conflicts while still avoiding the convection cells. In actual practice several other aircraft may also be in the area attempting to revise their routes. The ATS will have the computational capacity to handle trajectory change requests from many aircraft simultaneously.

In addition to ensuring that the approved trajectories returned to the aircraft are conflict-free for at least 10 minutes, the ATS also checks that the number of flights funneling through the narrow area between the cells does not exceed the capacity of the airspace. A capacity limit is needed to ensure that traffic can be handled safely in the event several aircraft in the area should unexpectedly deviate from their routes and create multiple short time-horizon conflicts. Although the capacity

of AAC-enabled airspace is expected to be two to three times higher than the current capacity, situations can occur, as illustrated here, when traffic flows converge unexpectedly and create the risk that the capacity will be exceeded in a small subset of a large region of airspace. Thus, ensuring that the traffic density remains within the capacity limit is essential for safety in the AAC enabled airspace.

After the approved trajectories have been uplinked and accepted by the respective aircraft, the ATS will update the flight plan database and monitor the track conformance of the aircraft with respect to the new trajectories.

It should be noted that if the AAC is to achieve the high capacity discussed above, aircraft must be equipped with 4-D flight management systems. These systems will have the ability to track specified trajectories during climbs, descents and turns with substantially fewer errors than is possible with today's flight management systems. However, AAC operations are feasible with current navigation and guidance equipment standards, although at a capacity well below the level that can be achieved with higher standards.

## **6 Transitional Steps toward AAC Operations**

It is not likely that a paradigm-shifting change in air traffic control, such as that represented by the AAC, can be accomplished by switching from the old to the new system in a single step at a chosen date. In light of the significant change controllers will experience in their roles and responsibilities, it is essential to plan for a stepwise transition to AAC operations. Initial steps, if properly planned, will reduce risk, build confidence in the concept and allow airspace users to gain early benefits. Furthermore, if users experience the predicted benefits, they will actively contribute to the process of bringing the more advanced and beneficial features into operational use.

One method of risk reduction in introducing AAC operations is to initially limit the kind and the start time of flight plan

changes the pilot can obtain from the ATS. For example, trajectory changes uplinked to the aircraft by the ATS could be constrained to start no earlier than about 6 minutes from the current time. Such a delay places the start of the trajectory change outside the controller's tactical separation monitoring and control time-horizon. A controller could therefore continue to be responsible for separating traffic manually without experiencing undesirable interference with his control decisions. During the countdown period to the start of the trajectory change, the controller would be made aware of the impending change by an appropriate message displayed on the controller's monitor. This delayed start will give the controller adequate time to cancel the change if he objects to it. An essentially equivalent approach to ensuring that the ATS trajectory change does not interfere with the controller's tactical separation clearances is for the ATS to delay the start of the change until after the aircraft has been handed off to the next sector. Although this transition step would yield only small reductions in controller workload and little in capacity gains, it would, however, let pilots and controllers gain experience with the concept of autonomous and controller-independent trajectory services.

A more significant transitional step will be the introduction of AAC operations to selected regions of airspace. At one or more Air Route Traffic Control Centers, AAC operations could be enabled in the entire airspace above a specified minimum altitude, for example above flight level 370. This airspace could be controlled as a single sector, referred to as a super-sector. Controllers would use current procedures to handle transitions to and from the AAC airspace. Tactical separation monitoring and control as well as strategic conflict resolution and pilot-directed trajectory planning would be performed by the AAC's ground based elements ATS and TSAFE. This level of operations would realize significant reductions in controller workload, an increase in airspace capacity and enhanced en route trajectory efficiencies. Access to this airspace would primarily be limited to CPDLC or equivalently

Table 1. Comparing characteristics of initial and mature AAC

Functions/ Performance	Initial	Mature
Data link message protocols	CPDLC message set	CPDLC with XML extensions
Trajectory specifications	Conventional flight plans and clearances	XML specified 4-D trajectories
Guidance and navigation requirements	Current standards and systems	FMS with 4-D guidance capability
Equipage types in AAC controlled airspace	Mixed equipped and unequipped aircraft	Predominantly equipped aircraft
Controller productivity gains compared to current	10-30%	Over 100 %
AAC sector design	Moderately enlarged, similar to current design	3-5 conventional sectors combined into one
Capacity gains compared to current standards	0-30% increase, depending on A/C equipage mix	100%-200% increase
Safety gains	50% reduction in operational error rate	90% reduction in operational error rate

equipped aircraft. Entry of unequipped aircraft into this airspace would be left to the discretion of the controller.

The AAC also provides a platform for automating descent and arrival control. An important motivation for the research that originally led to the design of the AAC was the difficulty in building arrival control tools that controllers would accept. By uplinking the trajectories generated for time-based arrival metering and final approach spacing directly into an aircraft's flight management computer, the AAC approach avoids controller workload issues that arise in manual delivery of advisories. Arrival metering under the control of the AAC will be feasible when a significant percentage of the airline fleet becomes equipped with CPDLC integrated with flight management computers. This is expected to occur by about 2012. In that time period the En Route Descent Advisor currently under development by NASA as a decision support

tool for controllers will become a candidate for adaptation to the AAC.

The final transition step would extend AAC operations to all altitude levels above 10,000 feet as well as to approach and departure corridors at selected hub airports. Procedural constraints could still be used to limit the type and timing of ATS-issued trajectories. For example, ATS authority could be restricted to certain types of trajectory changes, such as altitude changes only or route changes only. Another option is to give the sector controller the discretion to decide if or at what time to hand off an equipped aircraft to AAC control. In general, the characteristics of the traffic flow, the complexity of the control process and the percentage of equipped aircraft will determine how much trajectory authority can be delegated to the AAC automation and how much the controller needs to retain in order to achieve the best balance of safety, efficiency and capacity.

Table 1 compares the functionalities, equipage requirements and performance of initial and mature AAC operations. The primary difference that distinguishes the two levels is the onboard equipage standard for guidance and navigation systems. The initial system requires only that aircraft be equipped with a CPDLC/VDL data link and standard navigation and guidance systems. The mature AAC requires the adoption of more precise trajectory specifications as well as 4-D guidance systems onboard aircraft. Paielli has developed a trajectory specification method for this requirement using the Extensible Markup Language (XML), an international standard for passing structured information between computing systems [14].

The FAA defines operational errors, referred to in Table 1, as violations of required separation standards for which controllers are held to be responsible. A reduction in error rate has been chosen here as a proxy for an increase in safety. It should be mentioned that the FAA has expressed concern over an increase in error rates in recent years. The 50% reduction in error rates given for the initial AAC is based on the improved performance of TSAFE compared to Conflict Alert as well as on the estimated reduction in communication errors obtained by using a data link. The greater reductions given for the mature AAC are based on results of the safety analysis described in the next section. Only the mature AAC realizes the AAC's full potential for large increases in capacity, safety, and controller productivity.

## 7 Safety Analysis

The primary consideration in designing the architecture of the AAC was to achieve the highest practical level of safety. Because of the high level of autonomous control authority delegated to the ground-based elements of the AAC, it was essential to design the architecture of the system so as to ensure the integrity and continuity of control following failure of critical software and hardware components. By identifying the kinds of faults that can occur

during the operation of the system and determining how these faults influence collision risk, it is possible to estimate the overall safety of the system. Such a safety analysis using fault tree methodology has recently been conducted for the AAC [15].

The analysis considers a mature AAC in which aircraft follow prescribed 4-D trajectories that are transmitted to them via datalink. Four general types of faults that could result in loss of separation between aircraft were defined: faults under nominal conditions, faults due to incorrect information received by the aircraft, faults due to inability of aircraft to follow instructions, and faults due to ground system service interruptions. Parameters for the quantitative analysis were derived from historical data supplemented where required by assumptions regarding the future ATM environment. The level of safety achieved by the AAC appears to be increased significantly by features such as secure transmission of trajectories via data link, timely uplinking of resolution trajectories when conflicts are detected, and extended conflict-free time horizons that allow the traffic in the AAC controlled airspace to coast through ground system service interruptions with low collision risk. Further development and testing of the AAC system is required before a definitive statement can be made regarding achievable level of safety. However, preliminary results from the analysis yield a potential level of safety, as measured by expected time between collisions, which is significantly higher for the AAC than for the current system. Regulatory authorities will use these methods of analysis as part of the process for certifying that the AAC is safe for operational use.

## 8 Concluding Remarks

The proposed next-generation air traffic control system, the Advanced Airspace Concept (AAC), has the potential to accommodate a substantial increase in traffic by reducing the controller workload associated with tactical separation assurance tasks. The key technical approach behind the concept is a ground

system that provides automated and autonomous trajectory services and an independent backup system for separation assurance for aircraft via data link. In AAC enabled airspace, controllers would not be responsible for separation assurance of appropriately equipped aircraft; instead they would perform strategic control tasks and manage failure conditions. Several basic systems required for the AAC are being developed independently for other applications. These include the CPDLC/VDL technologies and the FAA's ERAM system. The two additional ground-based elements that are required for the AAC are the Automated Trajectory Server and the independent separation assurance system, TSAFE. Developmental software for these elements must be built and integrated into a test and evaluation system. Both simulations and field evaluations will be required in order to develop the final design specifications for the AAC. The transition from current to AAC operations can be planned in several steps that minimize risks while providing early benefits to airspace users. An initial quantitative analysis indicates that the mature AAC system has the potential to increase safety by substantially reducing the collision risk compared to that of the current system.

## References

- [1] Andrews J W. Capacity Benefits of the Advanced Airspace Concept, MIT Lincoln Laboratories Report No. 42PM-AATT-0014, Aug. 17, 2001.
- [2] Erzberger, H. The Automated Airspace Concept. *Proceedings of the Fourth USA/Europe Air Traffic Management R&D Seminar*, Santa Fe, New Mexico, USA, Dec. 3-7, 2001.
- [3] Erzberger H, and Paielli R. Concept for Next Generation Air Traffic Control System. *Air Traffic Control Quarterly*, Vol. 10, No. 4, pp 355-378, 2002.
- [4] Guiding Principles for Air Traffic Services Provided via Data Communications Utilizing the ATN, Builds 1 and 1A, RTCA DO-250, Jan. 11, 2000, published by RTCA, Inc, 1140 Connecticut Avenue, NW, Suite 1020, Washington, D.C. 20036-4008 USA.
- [5] Concepts for Services Integrating Flight Operations and Air Traffic Management Using Addressed Data Link, RTCA DO-269, June 12, 2001, published by RTCA, Inc, 1140 Connecticut Avenue, NW, Suite 1020, Washington, D.C. 20036-4008 USA.
- [6] McNally D, Erzberger H, and Bach R. A Controller Tool for Transition Airspace, *AIAA Guidance, Navigation, and Control Conference*, AIAA paper No. 99-4298, Portland, Oregon, Aug. 9-11, 1999.
- [7] McNally D, Engelland S, Bach R, Chan W, and Erzberger H. Operational Evaluation of the Direct-To Controller Tool 4<sup>th</sup> USA/Europe Air Traffic Management R&D Seminar, Santa Fe, New Mexico, Dec. 3-7, 2001.
- [8] Center-TRACON Automation System software, [http://www.ctas.arc.nasa.gov/project\\_description/sw\\_overview.html](http://www.ctas.arc.nasa.gov/project_description/sw_overview.html)
- [9] Coppenbarger R A, Lanier R, Sweet D, Dorsky S. Design and Development of the En Route Descent Adviser (EDA) for Conflict-Free Arrival Metering, *Proceedings of the AIAA Guidance, Navigation, and Control Conference*, Providence, Rhode Island, Aug. 16-19, 2004.
- [10] Robinson J E III, and Isaacson D R. A Concurrent Sequencing and Deconfliction Algorithm for Terminal Area Air Traffic Control, AIAA Paper 00-4473, *AIAA Guidance, Navigation, and Control Conference*, Denver, Colorado, 2000.
- [11] Jung C and Isaacson D. Development of Conflict-Free, Unrestricted Climbs for a Terminal Area Departure Tool, *AIAA 3<sup>rd</sup> Annual Aviation Technology, Integration, and Operations (ATIO) Tech. Meeting*, AIAA paper 2003-6794, Denver, Colorado, Nov. 17-19, 2003.
- [12] Slattery R and Zhao Y. Trajectory Synthesis for Air Traffic Automation. *AIAA J. Guidance, Control, and Dynamics*, Vol.20, No. 2, pp. 232-238, March-April 1997.
- [13] Erzberger H, McNally D and Foster M. Direct-To Tool for En Route Controllers, *New Concepts and Methods in Air Traffic Management*, Bianco L, Dell'Olmo P and Odoni A. editors, ISSN 1431-9373, Springer Verlag, Berlin, pp 178-198, 2001.
- [14] Paielli R. Trajectory Specification for High Capacity Air Traffic Control, NASA/TM-2004-212825, Ames Research Center, Moffett Field California.
- [15] Andrews J W. Safety Assessment Model for the Advanced Airspace Concept, 42PM-AATT-0018, M.I.T. Lincoln Laboratory, June 2004.