

EXPERIMENTAL ANALYSIS OF THE CONFLUENT BOUNDARY LAYER BETWEEN A FLAP AND A MAIN ELEMENT WITH SAW-TOOTHED TRAILING EDGE

**Lemes, Rodrigo Cristian, Catalano, Fernando Martini PhD.
USP - Universidade de São Paulo, São Carlos, SP – Brasil.**

Keywords: *Vortex Generators, Saw-Toothed, High-Lift.*

Abstract

The main purpose of this work was the experimental investigation of the effect of a saw-tooth trailing edge of a wing main element on the aerodynamics characteristics of a single flap. The saw-tooth trailing edge consists of triangles on the trailing edge of the main element of the wing in order to promote mixing between the higher-pressure flow from the lower surface with the flow on the upper surface. This mixing may reduce wing trailing edge separation and also inject vorticity into flap boundary layer, thus delaying separation. Therefore, more lift may be produced for less pressure drag. Extensive wind tunnel experiments were made for a series of saw-tooth trailing edge geometries. Forces and chordwise pressure measurements were performed for a two-dimensional wing with a single flap, as well as hot wire anemometry mapping of the confluent boundary layer. Flow visualization in the wing-flap gap was performed using a sublimation technique. Results show that the vorticity injected into the flap boundary layer by the saw-tooth trailing edge can delay flap separation up to 20%, and that the effect is dependent on saw-tooth geometry.

1 Introduction

One of the most effective devices to increase wing lift is the trailing edge flap. With the flap it is possible to produce more lift for the same incidence angle and at a lower velocity, enhancing take-off and landing performance.

For take-off it is also important to increase the maximum wing CL that is not always achieved with a flap. Therefore, sometimes a slat or leading edge flap is also necessary. Single flaps have difficulty producing a considerable increase on CL_{max} mainly due to the turbulent separation on the suction surface. Higher performance can be achieved by using multi-element fowler flaps but their mechanisms are complex and heavy. The ideal flap would be a single element fowler flap which could produce high maximum CL with a low boundary layer pressure drag penalty. With this kind of flap, in some cases, the leading edge high lift devices would be not necessary. The use of vortex generators is widely employed in aeronautical engineering to reduce turbulent separation on the wing and reduce pressure drag. The effect of vortex generators on wing performance was first studied by Taylor [1] in 1945. However, in general, vortex generators are not practical at cruise speeds and also produce parasite drag [2,3]. Also, it is not easy to locate vortex generators at the flap upper surface in order to inject enough turbulence into the boundary layer due to the lack of space between main element and flap in the stowed position. Novel trailing edges have been proposed by Werle et al [4] in order to alleviate separation on airfoils and wings. This consists on waving the trailing edge in order to promote mixing between the higher-pressure flow from the lower surface with the flow on the upper surface. This mixing reduces wing trailing edge separation, increasing maximum lift values. For the case of a wing main element and flap waving the main element trailing edge would make flap stowing

impossible. The present work proposes to experimentally study a similar method of mixing flow at the trailing edge by using a saw tooth trailing edge rather than using waves. The main purpose of this study is to analyse experimentally the effect of the saw tooth trailing edge of the main element on the flap aerodynamic performance.

2 Experimental Set-up

The experiment was conducted in the Wind tunnel of Aerodynamic Laboratory of Sao Carlos Engineering School, University of Sao Paulo. The Wind tunnel is closed circuit and closed working section, the height dimensions of which are: 1.75m width, 1.30m height and 4m length. Turbulence level and maximum velocity are 0.25% and 50m/s respectively. The wing model has two elements with a flap and main element as showing in Fig. 1. The flap and main element are made of fiberglass with steel spars fixed to circular end plates to simulate a two-dimensional wing. The main dimensions of the wing are in Table 1. Using end plates does not assure two-dimensional flow, especially in high lift wings such as this model. However, at the center of the wing, where chordwise pressure measurements are performed the three-dimensional flow induced by the secondary vortices at the end plate is minimal. Also, the comparative analysis of this work assumes that any secondary vortex effect at the center of the wing will be present in both configurations: with and without the saw-toothed trailing edge. The flap incidence angle can be changed but within a small range due to the subsequent change in the wing/flap gap and overlap. A total of 90 chordwise pressure taps were used to measure pressure coefficient distribution on both surfaces of the wing main element and flap. The pressure coefficient distributions were measured by two mechanical D48 scanivalves fitted with ± 1.0 -psia setra transducer. The wing was positioned in a vertical position attached to the aerodynamic balance below the tunnel floor. The aerodynamic balance has only two

components so that drag and side force (lift) were measured for a range of incidence angle of -4° to 20° . The two-component balance used is of the strain gage type and has a measurement accuracy of $\pm 0.7\%$ for maximum loading. Therefore, accuracy for Lift and Drag are ± 1.0 N and ± 0.19 N respectively. Incidence angle was measured with an accuracy of ± 0.1 deg.

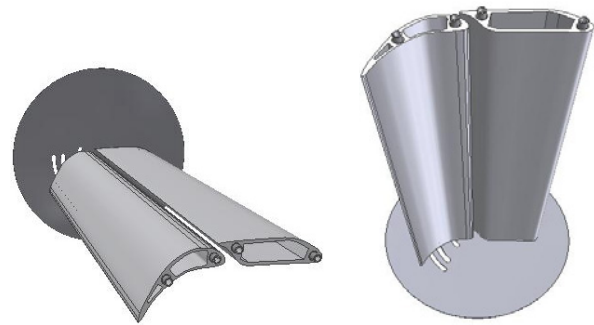
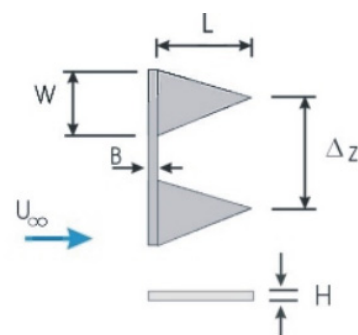

Fig. 01: Two element model wing.

Table 01: Model wing Main dimentions.

	Main Element	Flap
Reference area	0.399 m ²	0.396 m ²
Span	1.00 m	1.00 m
Chord	0.186 m	0.170 m



Vortex Generator Dimensions :	H (mm)	L (mm)	W (mm)	Δz (mm)	B (mm)
Generator (3%)	1.00	5.00	8.00	12.70	3.00
Generator (5%)	1.00	9.00	9.00	18.00	3.00

Fig.02. Geometrical dimensions of the saw-tooth pairs.

EXPERIMENTAL ANALYSIS OF THE CONFLUENT BOUNDARY LAYER
BETWEEN A FLAP AND A MAIN ELEMENT WITH SAW-TOOTHED
TRAILING EDGE.

A series of saw-tooth plastic strips were glued to the trailing edge of the main element. The saw tooth geometry was defined by the size of the triangular tooth and the distance between each of them. Figure 02 shows the saw tooth trailing edge dimensions and Figure 04 the attachment to the model wing main element trailing edge. The results of two types of saw tooth strips only will be presented in this work: one with a height of (ST3%) of the main element chord and the other with (ST5%). The saw tooth trailing edge changes the gap and overlap between main element and flap in comparison with the clean wing. Therefore, the clean wing case was tested with an increase of the longitudinal trailing edge dimension of 2% and 3% of the main element chord in order to assure the same gap and overlap of the wing with the saw tooth trailing edge of 3% and 5% respectively as mentioned above. The experiments were conducted at an average Reynolds number of 400.000 and no trip wire or roughness strip was attached on the leading edge so that transition was free and laminar bubbles were expected to occur.

The confluent boundary layer and shear layer between main element and flap was measured using a single hot wire probe positioned in 465 points in a plane at 0.25% downstream of the flap leading edge as shown in Figure 03.

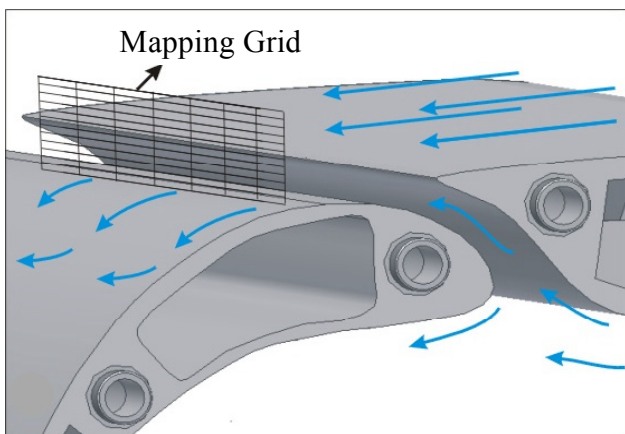

Fig.03. Mapping grid of the hot wire anemometry measurements.

Table 02. Main element and flap cardinal points.

MAIN ELEMENT (mm)				FLAP (mm)			
Upper Surface		Lower Surface		Upper Surface		Lower Surface	
X	Y	X	Y	X	Y	X	Y
0	0	2.1	-4.3	0	0	5	-2.5
1.1	4	4.1	-6.3	-1.6	5	10	-2
3.1	7	9.1	-8.7	-1.5	10	20	1.8
9.1	12	19.1	-10	0	16	35	8
19.1	19.1	39.1	-10.1	4.52	24	45	12.2
39.1	29	79.1	-10.5	8.2	28.9	55	15.2
49.1	32	119.1	-12.1	15	35	60	16.4
59.1	34	129.1	-12.3	25	41	65	17.6
74.1	35	135.1	-11.6	35	45	70	17.6
89.1	34.5	142.1	-9.2	45	46.9	75	17.8
119.1	33	148.1	-5.8	55	47.7	78	17.7
149.1	30	153.5	-1	60	47.9	85	17
169.1	27.8	158.1	5	70	47	95	15
183.9	25.8	164.1	13	76	46	105	12.2
		169.1	17	85	43.5	125	4.5
		175.1	20	95	39.7	145	-4.2
		179.1	22	105	34.7	162	-12
		182.6	23	120	25.2	165	-13
		184.1	24.5	135	14.6	168.3	-12.7
		183.9	25.8	155	0		
				165	-8		
				168	-11		
				168.3	-12.7		

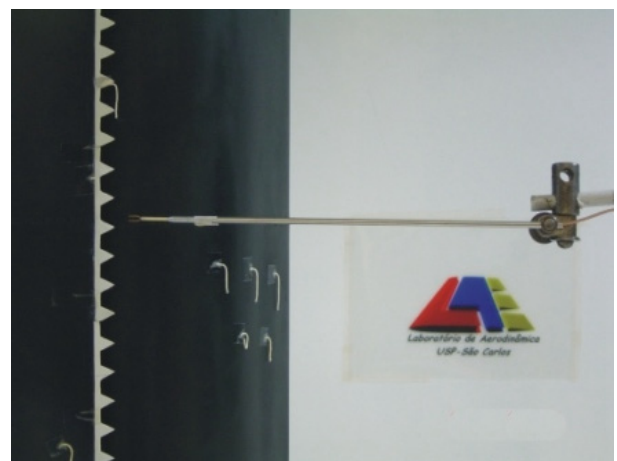

Fig.04. Hot wire anemometer measurements.

3 Results and Discussion

In Figures 05 and 06 the effect of the saw-tooth trailing edge mixing on the flap separation as well as on its suction peak can be seen. The increase of attached flow was approximately 20% and 46% for the ST3% and ST5% respectively for the range of wing incidence angles higher than 8deg. For low incidence the effect is more intense only for the ST5% and there is also an increase on the flap suction peak as shown in Figure 05. However, for the entire range of incidence angles tested there was an increase in suction on the downstream end of the wing main element, showing that there was an improvement on tangential velocity in that region. This effect combined with the injection of turbulence on the flap boundary layer may improve flap aerodynamic performance. These effects did not affect the laminar separation bubble located at the wing main element upper surface. The laminar separation bubble is shown in Figures 06 e 07 by the letters LS (laminar separation), T (transition) e TR (turbulent reattachment). For low incidence angles and flap at 4deg the effect of the saw-tooth trailing edge also appears as a global increase of circulation. This effect can be confirmed in Figure 08 by the increase of suction and pressure on the upper and lower surface of the front part of the wing main element respectively.

From Figure 08 it can be seen that there is an improvement on the CL-alpha curve for the flap at 12deg and the ST5% but very small effect for this configuration with the ST3%. Although there is an improvement on CD for both ST5% and ST3% these rather encouraging results should be confirmed by total head wake integration measurements in order to compare the profile drag.

From the analysis of the previous results it is clear that the effect of the saw-toothed trailing edge depends on the wing geometry, gap and overlap and saw-tooth geometry and that a proper saw-toothed trailing edge must thus be designed for each new wing.

The hot wire mapping measurements showed very interesting results in both the confluent

boundary layer and at the flap surface. Comparing the cases with and without the saw-toothed trailing edge in Figures 09 to 13 it can be seen that there is an intermittent vortex formation on the saw-tooth that injects turbulence and energy into the flap boundary layer as the tangential speed at the flap surface also increases. The tendency is for downstream mixing-up of this stratification to occur which affects beneficially the turbulent separation. Measurements are underway of the boundary layer at different downstream positions on the flap upper surface in order to implement the conclusions, but the sublimation flow visualization has confirmed the results as shown in Figures 14 and 15. The sublimation technique is used to detect the transition front as the naphthalene sublimates under turbulence, in this way the results of Figures 14 and 15 show that laminar flow has increased but this effect occurs due to the stratified flow pattern generated by the saw-toothed trailing edge where there are transition spots and laminar flow forming a “zigzag” transition front. The results from mapping the flow just behind the saw-tooth trailing edge showed that there remains a field for the of study different geometries for the saw-tooth in order to produce a better interaction between the vortices generated and the flow from the wing/flap gap.

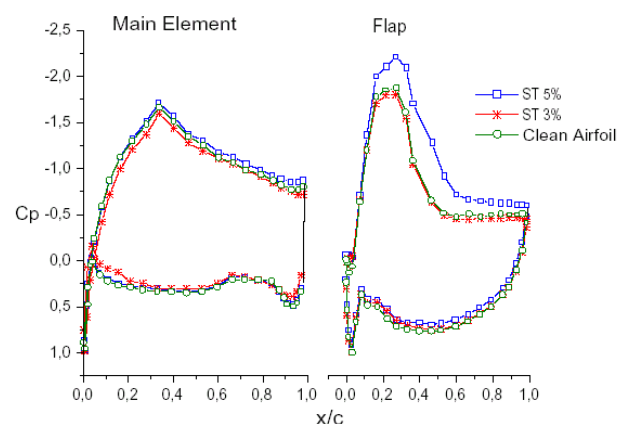

Fig. 05. C_p vs. x/c at -2-deg incidence angle and 8-deg flap angle. Comparison of different saw-tooth configurations and clean airfoil for $Re_y = 390000$.

EXPERIMENTAL ANALYSIS OF THE CONFLUENT BOUNDARY LAYER BETWEEN A FLAP AND A MAIN ELEMENT WITH SAW-TOOTHED TRAILING EDGE.

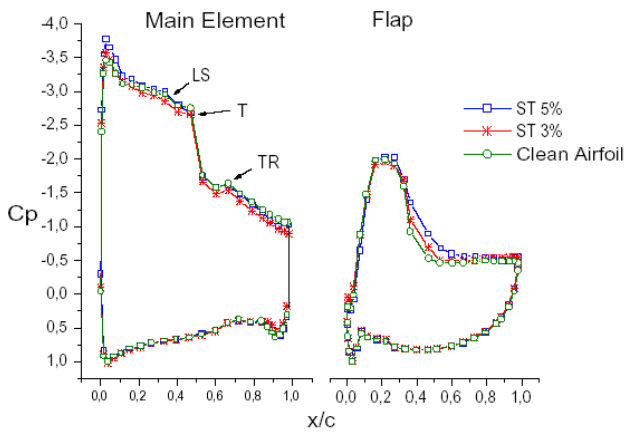

Fig. 06. C_p vs. x/c at 10-deg incidence angle and flap at 8-deg. Comparison of different saw-tooth configurations and clean airfoil for $Re_y = 380000$.

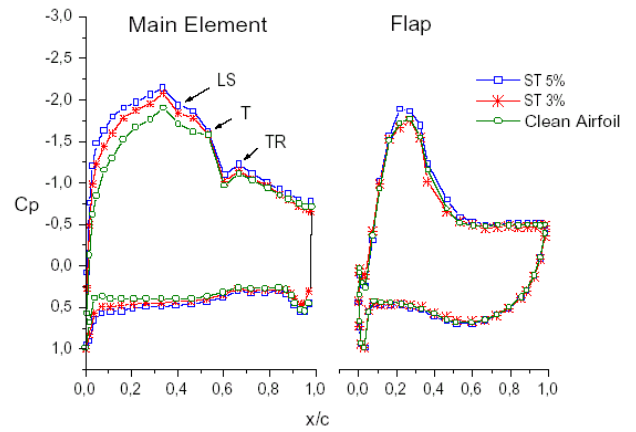

Fig. 07. C_p vs. x/c at 4-deg incidence angle and flap at 4-deg. Comparison of different saw-tooth configurations and clean airfoil for $Re_y = 395000$.

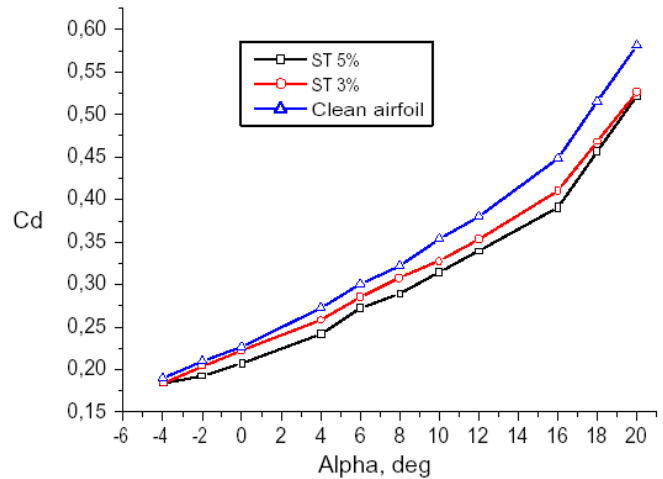
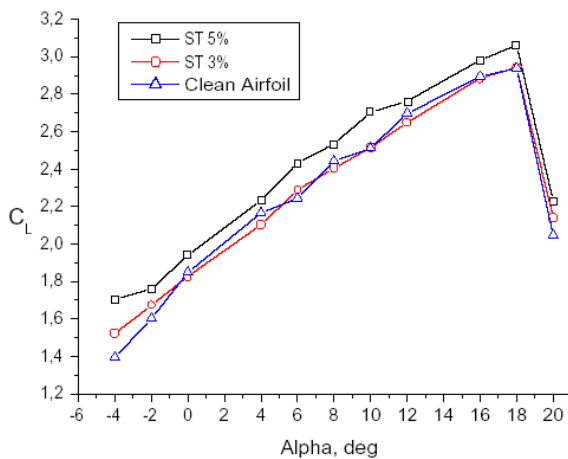

Fig. 08. Lift and drag coefficients for flap at 12-deg. Comparison of different saw-tooth configurations and clean airfoil at $Re_y = 340000$.

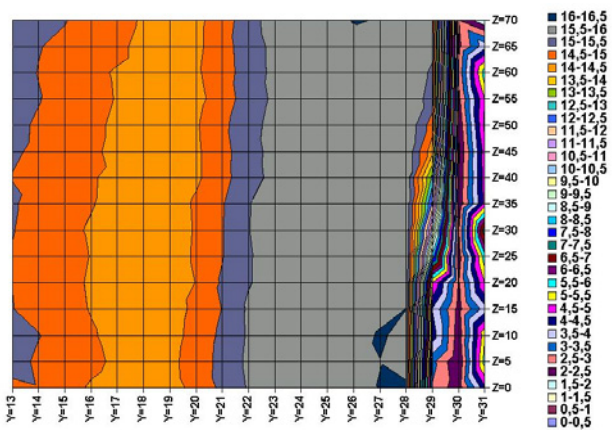

Fig. 09. Topography of clean airfoil at $Re_y = 350000$. $\alpha = 10$ -deg and flap at 12-deg.

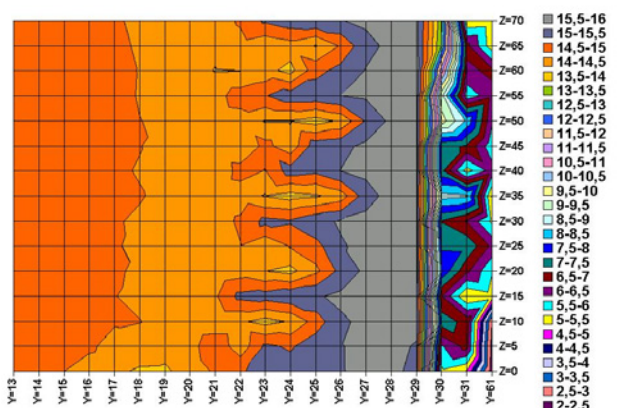

Fig.10. Topography of airfoil with ST3% at $Re_y = 350000$. $\alpha = 10$ -deg and flap at 12-deg.

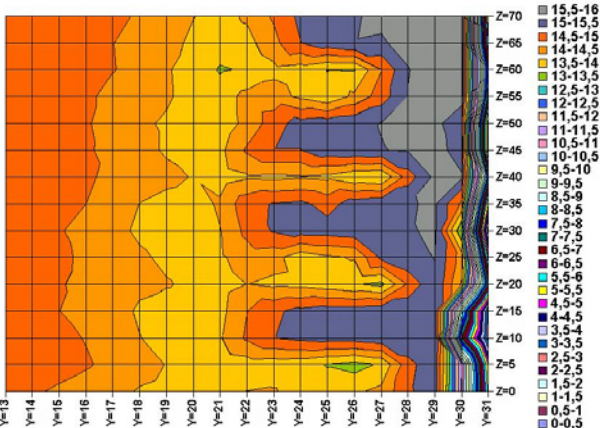

Fig.11. Topography of airfoil with ST5% at $Re = 350000$. $\alpha = 10$ -deg and 12-deg flap angle.



Fig.14. Visualization effect of saw-tooth on upper surface flap at $Re = 400000$. $\alpha = 10$ -deg and flap at 12-deg.

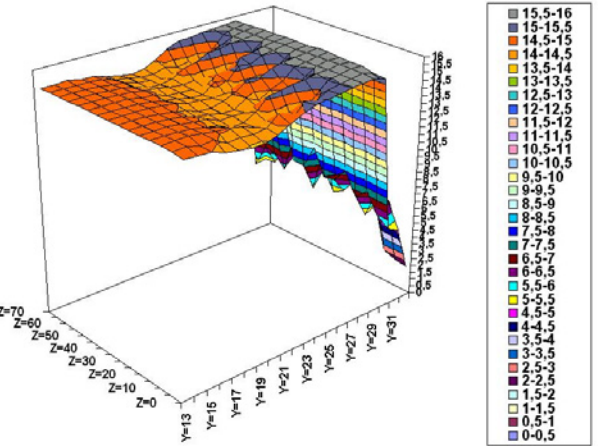

Fig.12. Three-dimensional of airfoil with ST3% at $Re = 350000$. $\alpha = 10$ -deg and flap at 12-deg.

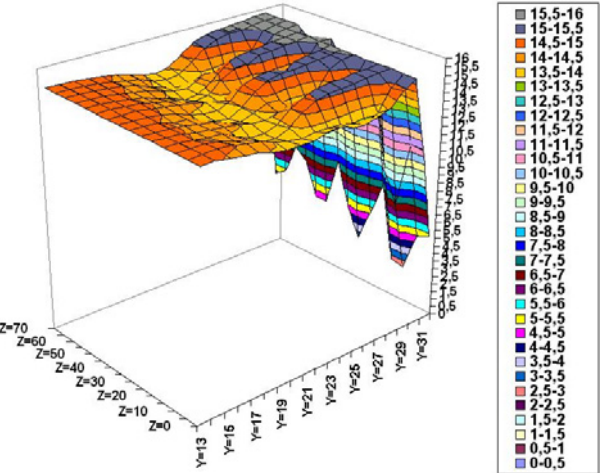

Fig.13. Three-dimensional of airfoil with ST5% at $Re = 350000$. $\alpha = 10$ -deg and flap at 12-deg.

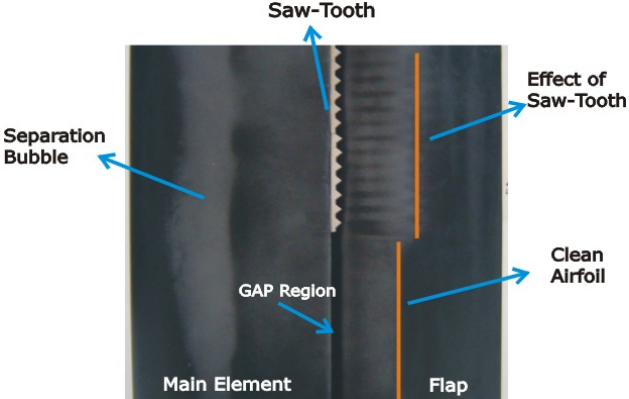

Fig.15. Visualization effect of saw-tooth and clean airfoil over upper surface flap at $Re = 400000$. $\alpha = 10$ -deg and flap at 12-deg.

4 Conclusions.

An experimental study was carried out in order to evaluate the effect of a saw-toothed trailing edge of a main wing on the aerodynamic performance of a single flap. The results showed that vorticity is formed at the saw-toothed trailing edge through the mixing between the flow from the pressure side to the suction side at the main wing and flap gap. This vorticity is injected inside the flap boundary layer delaying separation. For the wing model

tested the separation was delayed up to 45%. However, the generalization of these results depends on new experimental tests with a wing/flap model that could change gap and overlap. Performing such tests, the relationship between saw-toothed trailing edge geometry and the gap and overlap could be optimized.

5 References

- [1] Storms B L and Jang C S. Lift enhancement of an airfoil using a gurney flap and vortex generators. *Journal of Aircraft*. Vol. 31. No. 3. pp 542-547. 1994.
- [2] Taylor H D. The elimination of diffuser separation by vortex generators. *United Aircraft Corp.*. R-4012-3. East Hartford. CT. 1947.
- [3] Rao D M and Kariva T T. Boundary-layer submerged vortex generators for separation control – An exploratory study. Proceedin of the 1st National Fluid Dynamics Conference. Cincinnati OH. AIAA. Washington. DC. pp. 839-846. 1988.
- [4] Werle, M. J. and Paterson, W. M. Trailing-edge Separation/Stall Alleviation. *AIAA Journal* Vol 25, No. 4 April 1987.
- [5] Lin J C. Robinson S K and McGhee R J. Separation control on high-lift airfoils via micro-vortex generators. *Journal of Aircraft*. Vol. 31. No. 6. pp 1317-1323. 1994.
- [6] Kerho M. Hutcherson S.. Blackwelder R F and Liebeck R H. Vortex generators used to control laminar separation bubbles. *Journal of Aircraft*. Vol. 30. No. 3. pp. 315-319. 1993.
- [7] Anderson J D. *Fundamentals of aerodynamics*. 3rd edition. McGraw-Hill Series in Aeronautical and aerospace Engineering. 2001.