

THE EFFECT OF WING TIP BLOWING ON THE VORTEX DRAG

**R.F.F. Coimbra Dr.(EMBRAER rogerio.coimbra@embraer.com.br),
F.M. Catalano PhD.(Aerodynamic Laboratory USP Brazil catalano@sc.usp.br)**

Keywords: *Wing tip blowing, induced drag, Coanda jet*

Abstract

Experimental work has been conducted to evaluate the effect of wing tip blowing on the vortex drag of a rectangular low aspect wing at low speed. A novel tip blowing system is presented which consist of three Coanda type jets. The jets can be vectored to produce a better tip vortex attenuation. Wind tunnel tests were performed for measurements of Lift, Drag and Pitching moment for a large number of combinations of jet vertical angles and position. The tests were conducted at constant Reynolds number for incidence angles from -4 to 22 degrees. Results indicated an increase in Lift and pitching moment with an inherent decrease in drag for most of the configuration tested

1 Introduction

Vortex drag or induced drag reductions through tip devices have three main objectives: first, there is the problem of the decay of the wing tip and flap wake vortices left in the atmosphere after a high loaded aircraft take-off [1]; secondly there is the improvement of climb-out and climb maneuvers, and finally induced drag may also be reduced at cruise. Fixed tip devices or passive systems such as winglets [2], tip sails [3,4] and wing tip shapes [5] have been successful in alleviating induced drag in climb maneuvers but not always at cruise. Also, such devices cannot couple well with the problem of the trailing vortex left in the atmosphere. Passive systems must be designed as a compromise between the three objectives pointed out above so that best overall efficiency is difficult to achieve. On the other hand, active systems can be optimized for each maneuver

requirement as their effect can be changed and also switched off when necessary. A large number of studies [6-9] have been carried-out in order to show the potential benefits of wing tip blowing as an active vortex attenuating system. These tests usually involved large jet momentum coefficients and the jet sizes were a large fraction of the wingtip chord. Also, the required jet mass-flow rates and momentum coefficients were large. In most cases, the jets were exhausted in the plane of the wing and normal to the free-stream direction. Recently, Simpson et al [10] introduced a different type of jet system, which was based on the Coanda effect. This type of jet can vectorate the mass flow against the vortex and its size is relatively small compared with the tip chord as well as the mass flow rate. In this work, the proposed system consists of three independent Coanda jets, which can be vectored in different directions (see Figure 1) in a tentative to oppose mass flow against the vortex flow in a similar manner to that of Spillman [3] with his tip sails. Experimental work was performed for a large combination of jet flow lateral angles and positions at tip chord for incidence angles from -4 to 22 degrees always comparing with that of the blowing off case.

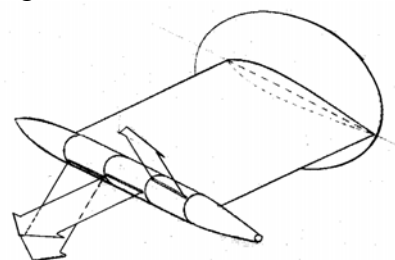

Figure 1 Three Wing Tip "Coanda" jets.

2 Experimental Set-up

The experimental model was a semi-span wing of 0.29m with a 0.25m chord. The wing profile was a NACA 65₃-018 and the model was attached to a horizontal three-component balance as is shown in Figure 2. The three Coanda jets module were fixed to a cylindrical “tip tank” just for the convenience of enough space for the air manifolds and internal plenum chambers to assure the most uniform jet possible.

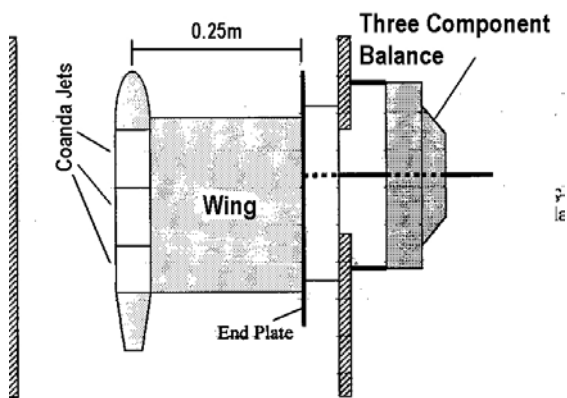

Figure 2 Experimental Set-up

Each Coanda Jet module has an air supply manifold with mass flow controlled by a flowmeter. Details of the jets dimensions and chambers are shown in Figure 3.

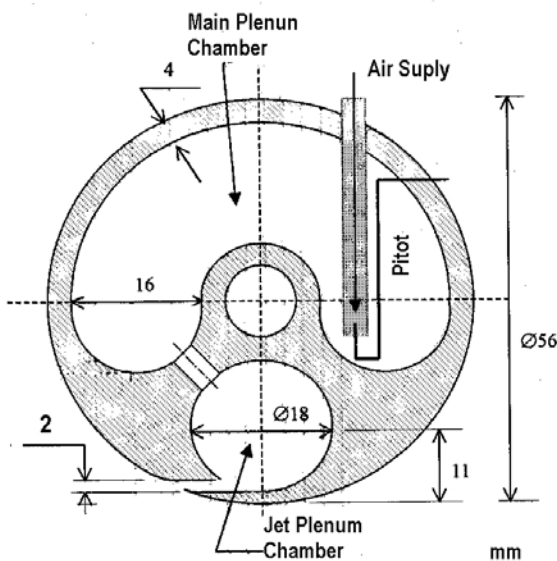

Figure 3 Jet module geometry and dimensions

Tests were conducted in an open circuit straight through wind tunnel with a 0.6 x 0.6 m test section at an average Reynolds Number of 4×10^5 . Turbulence intensity was 0.5% at 30m/s. Figure 4 shows the wing model in the wind tunnel working section as well as the circular end plate at the wing root to avoid wall boundary layer interference. All the results were corrected for wall interference such as buoyancy and blockage.



Figure 4 Model inside the wind tunnel

Limited smoke flow visualization tests were performed with a small wing model in a smoke wind tunnel in order to pre-select best jet configuration, avoiding in this way a large number of useless tests. The model consisted of a full span wing with two tips scaled from that proposed but with just one tip capable of blowing so that comparison of blowing off and on could be made. A total of 63 configurations were tested in the smoke tunnel from which 43 configuration were selected for the wind tunnel experiments. The selection criteria was on the spanwise movement of the vortex core and its diameter in a plane 1.5 chord downstream the wing tip. A typical picture of the smoke filaments flow visualization is shown in Figure 5 where the lower tip is blowing.

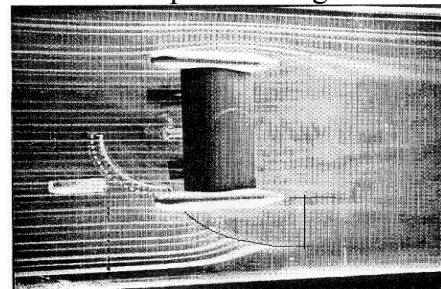

Figure 5 Flow visualization with smoke stream

It was thus decided to test lateral angles in steps of 5° from 0° to 45° for the first module, 0° to 30° for the central one and 0° to 15° for the rear module. The configuration nomenclature and reference positions are shown in Figure 6.

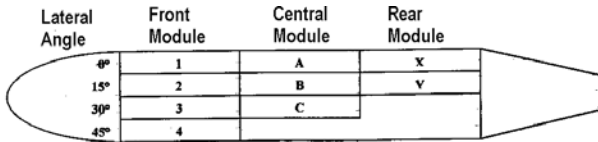

Figure 6 Tip jet modules nomenclature

For example: tip blowing 1CY means that the first module is blowing at 0°, central module at 30° and rear module at 15°. The 43 configurations tested were divided into three categories: single jet, double jets and triple jets and the jet position combination based on the nomenclature of Figure 5 as shown in Table 1:

Table 1 Jet configurations tested

Single Jet			
1	4	C	
2	A	X	
3	B	Y	
Double Jet			
1A	3B	AX	
2A	4B	BX	
3A	1C	CX	
4A	2C	AY	
1B	3C	BY	
2B	4C	CY	
Triple Jet			
1AX	2BX	4CX	3CY
2AX	3BX	2BY	4CY
3AX	4BX	3BY	1AY
4AX	3CX	4BY	1BY

2.1 Test Conditions

The three-component balance used is of the strain gage type and has a measurement accuracy of ± 0.7% on maximum loading. Therefore, accuracy for Lift, Drag and Pitching Moment are ±1.0N, ±0.19N and ±0.02Nm respectively. Incidence angle was measured with an accuracy of ±0.1 deg. Jet momentum

coefficient C_μ was calculated using the following equation:

$$C_\mu = 2 \frac{P_e S_j}{q_\infty S_W} \quad (1)$$

Where P_e is the total pressure at module plenum chamber, q_∞ the free stream dynamic pressure and S_j and S_W are the jet and wing area respectively.

Testes were performed under the following conditions:

Table 2 Test Conditions

Flow conditions	Single Jet	Double Jet	Triple Jet
q_∞ (N/m ²)	369.72	362.81	368.61
T_o (k)	293.15	292.47	291.17
ρ (Kg/m ³)	1.132	1.137	1.142
μ (Kg/m.sec)	1.8x10 ⁻⁵	1.797x10 ⁻⁵	1.792x10 ⁻⁵
U_∞ (m/sec)	25.5	25.25	25.39
NR_{ey}	401.88	399.672	405.243
M	0.0744	0.0740	0.0742
Jet Conditions			
P_e (Pa)*	16.637	16.822	14.724
P_{Dj} (mmH ₂ O) *	214.83	217.23	190.14
U_j (m/séc) *	61.01	61.21	57.12
U_j/U_∞ *	2.387	2.424	2.249
C_μ **	0.166	0.342	0.442
m (Kg/sec) **	0.0629	0.1268	0.1784
(*) For each module, (**) total value			

3 Results and Discussion

Because of the large number of configurations tested only data reduction of the best results will be presented for the three categories: single, double and triple jets. However, some discussion will be presented on the negative effects of each configuration. The data presented is always referred to the blowing off case.

Single Jet: The single jet configurations that presented best overall results were the X, Y, A, C and 4. Figure 7 shows CL x Alpha curves of the best results for the single jet configuration. As expected from previous work [6,11] jets located at the rear of the chord tip are more

effective in Lift enhancement. Also it is clear from Figure 7 that Jet 4 produces a downward lateral lift due to the Coanda effect at the cylindrical tip. However, Jet 4 was chosen because of its effect on the C_D as can be seen in Figure 8. Surprisingly, Jet 4 produces less drag at low incidence rather than at high incidence angles. This is probably due to the shift of the lift produced by the Coanda effect to the downstream direction when the interaction between jet and vortex increases at high incidences. This effect also reflects on the pitching moment results (Figure 9) with Jet 4 producing less nose down moment than the blowing off case. The others jet configurations produce an increase in pitching moment as a direct result of lift enhancement.

Double Jets: 1A, 3A, 2B and CX are the double jet configurations, which presented best performance. Lift enhancement is quite large and similar between the jet configurations as it can be seen in Figure 10. The exception is Jet 3A where the effect was still large but lift slope decreased. This result is in accordance with the single jet case, as the effect improves as the front jet moves to 1A. Drag results shown in Figure 11 are also very similar at low incidences but best overall performance is achieved with Jet CX in which induced drag reductions are larger. Therefore, Jet CX also shows the best enhancement on aerodynamic performance as shown in Figure 12.

Triple Jets: The triple jet configurations selected are: 4AX, 4BX, 4CX, 3CX and 3BY. A large increase in Lift was achieved for all the selected configurations as is shown in Figure 12. This effect is almost independent of the jet positions, although Jet 3CX and 3BY show a slightly bigger increase in Lift. Also Lift curve inclination has increased for all jets up to 12 degrees when mutual effect between the “tip-tank” flow and the jets flow shift the inclination back. This increase in effective aspect ratio with the enhancement in Lift led to the dramatic increase on the wing model aerodynamic efficiency as shown in Figure 14. The Drag polar also shows a large improvement for all jets especially at high incidences (Figure 15).

The potential flexibility of operation of an active system as that proposed is shown in Figures 16 and 17. It is possible to change the positions of the jets from 3A or 3BY to CX in order to maintain best performance with reference to climb rate and maximum range.

4 Conclusions

Wing tip blowing using a three vectored Coanda Jets combination was investigated in wind tunnel experiments in order to show the effect on the aerodynamic characteristics of a low aspect ratio wing. Results showed potential benefits in combining the three Jets on the aerodynamic characteristics of a wing. The optimization of the tip Jet flow for each operational maneuver may result in improvements for the whole flight envelope from climb to maximum range. However, some tests are still required at cruise configuration and low jet coefficients in order to accurately study the potential benefit of three Coanda vectored Jets.

5 References

- [1] Rossow, V.J., and Tinling, B.E. Research on aircraft/vortex wake interaction to determine acceptable level of wake intensity, *Journal of Aircraft* Vol 25 no. 6 pp481-492, 1988.
- [2] Van Dam, C.P., Holmes, B.J., & Pitts, C. Effect of winglets on performance and handling qualities of general aviation aircraft. *Journal of Aircraft*, Vol 18 no. 7, pp 587-591, 1981.
- [3] Spillman, J.J. The use of the wing tip sails to reduce vortex drag. *The Aeronautical Journal* pg 387-395, September 1978.
- [4] Traub, L.W. Aerodynamic effects of delta planform tip sails on wing performance. *Journal of Aircraft*, Vol 31 no. 5 pp 1156-1159, 1994.
- [5] Coimbra, R.F.F. & Catalano, F.M. An experimental study on wing tip devices for agricultural aircraft, *22th ICAS congress*, CD-rom proc., Sept. 2000.
- [6] Tavella, D. et al. The influence of tip blowing on rectangular wings. *AIAA paper no. 85-5001* oct. 1985.
- [7] Wu, J.M. Vakili, A.D. & William, F. Aerodynamic interaction of wing tip flow with discrete wing tip jets. *AIAA paper no. 84-2206* Aug. 1984.
- [8] Tavella, D. et al. Measurements on wing tip blowing. *NASA CR-176930*, Jun 36p 1985.

- [9] Mineck, R.E. Study of potential benefits from spanwise blowing at wing-tip. *NASA TP-3515* June 1995.
- [10] Simpson, G., Ahmed, N.A. & Archer, R.D. Improvement of a Wing's aerodynamic efficiency using Coanda tip jets. *Journal of Aircraft Vol. 37 no.1* 2000.

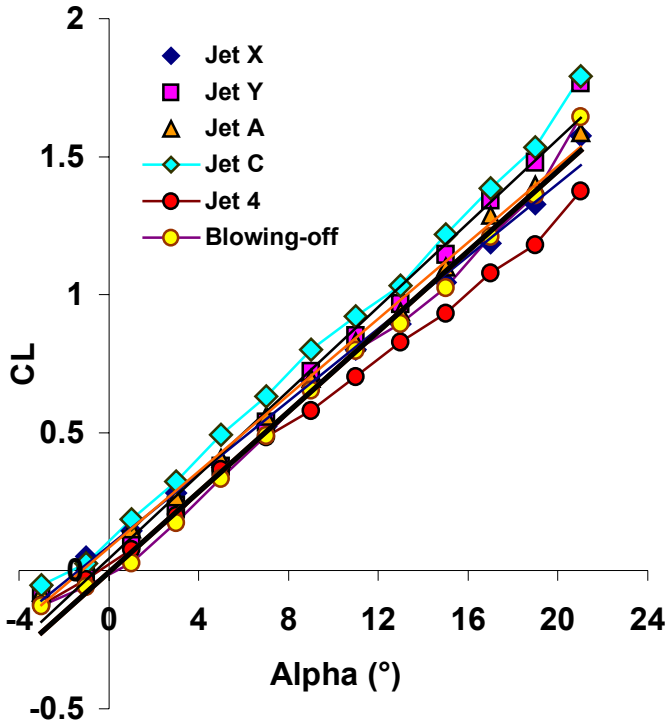

Figure 7 Single jet lift to alpha curves.

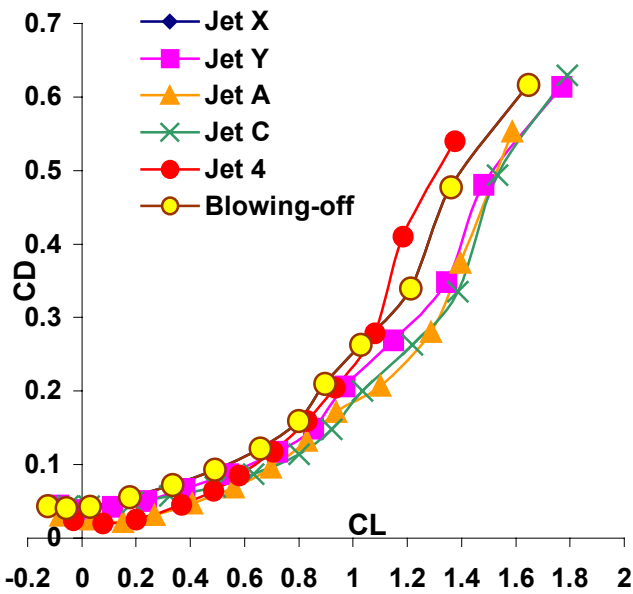

Figure 8 Single jet Drag polar.

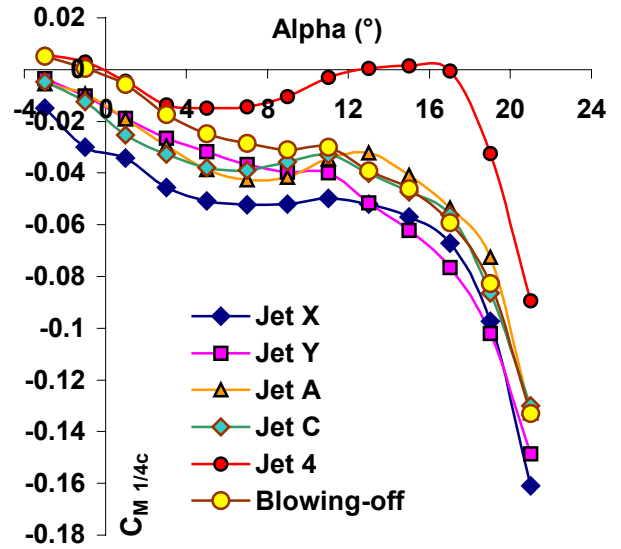

Figure 9 Pitching Moment results, Single Jets.

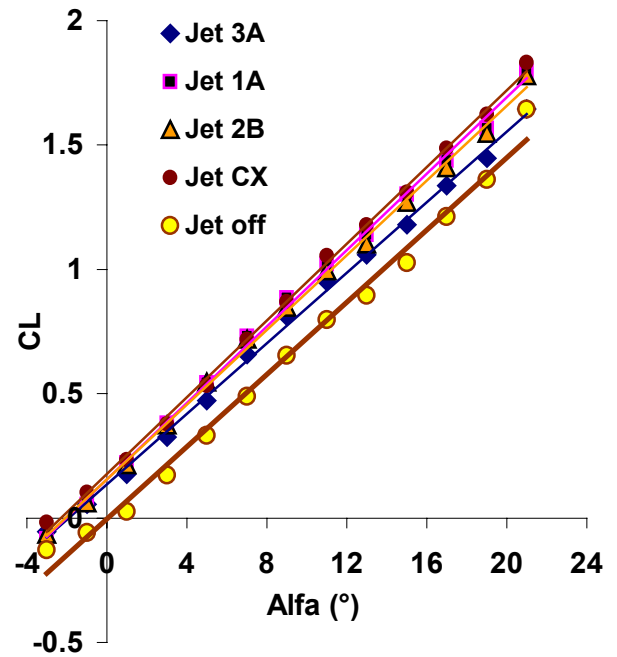

Figure 10 Double Jets Lift to alpha curves.

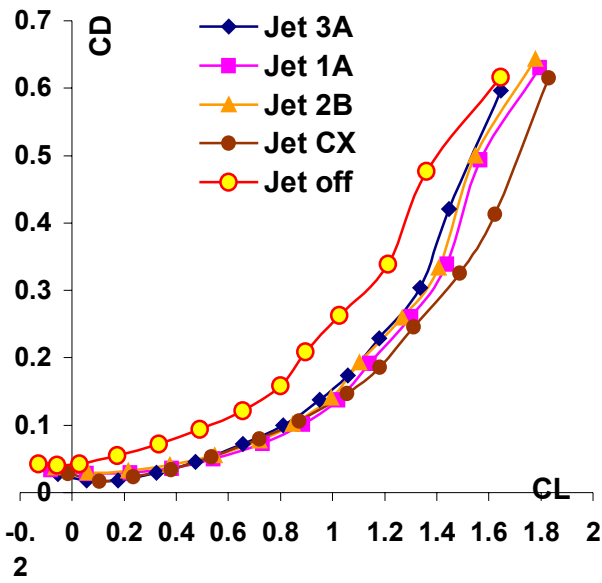

Figure 11 Drag polar for Double jets.

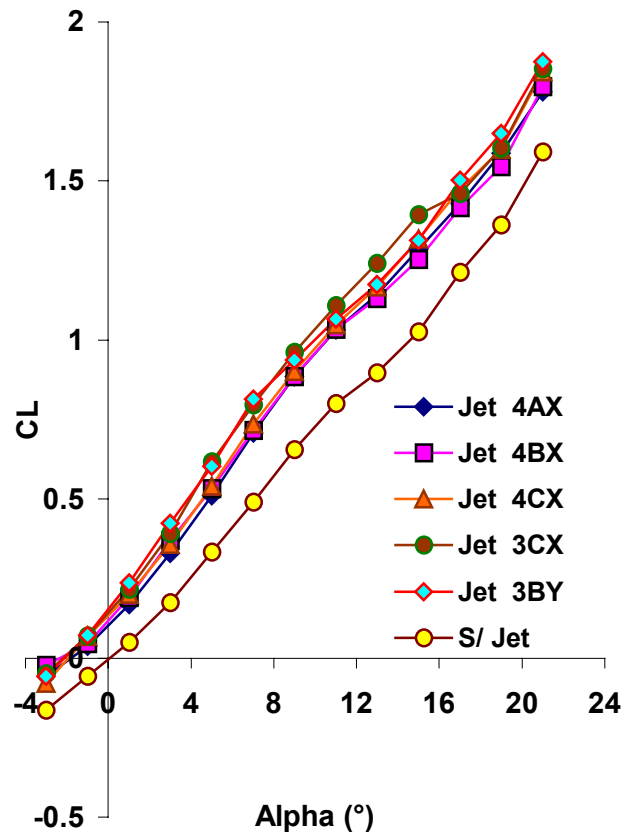

Figure 13 Lift curves for Triple Jets.

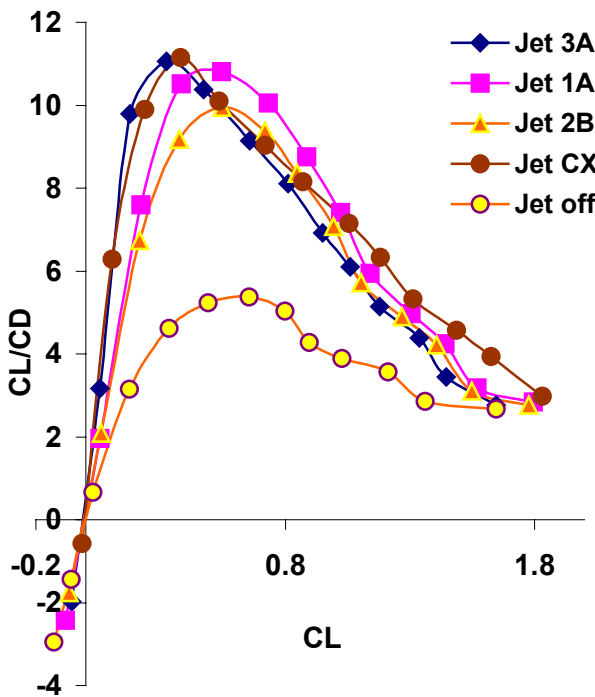

Figure 12 Wing efficiency with Double jets.

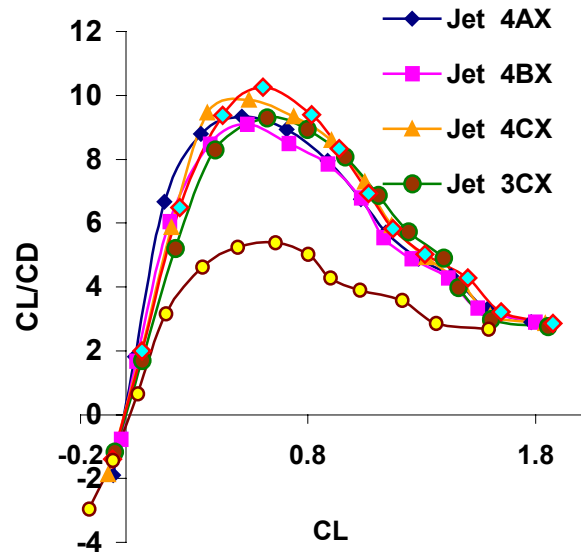

Figure 14 Wing efficiency with Triple Jets.

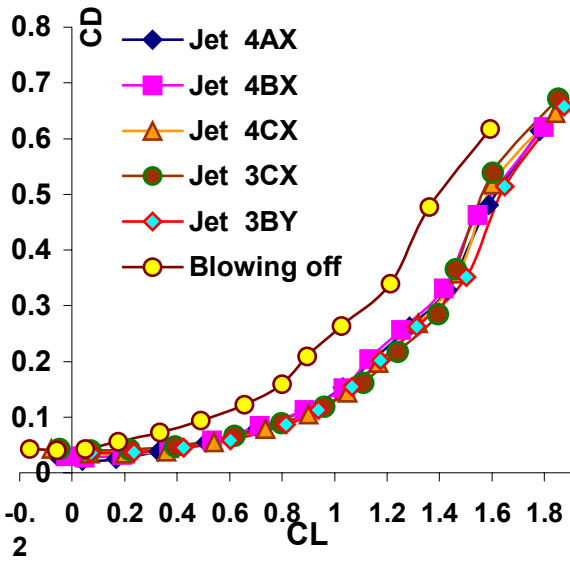

Figure 15 Drag polar for Triple Jets.

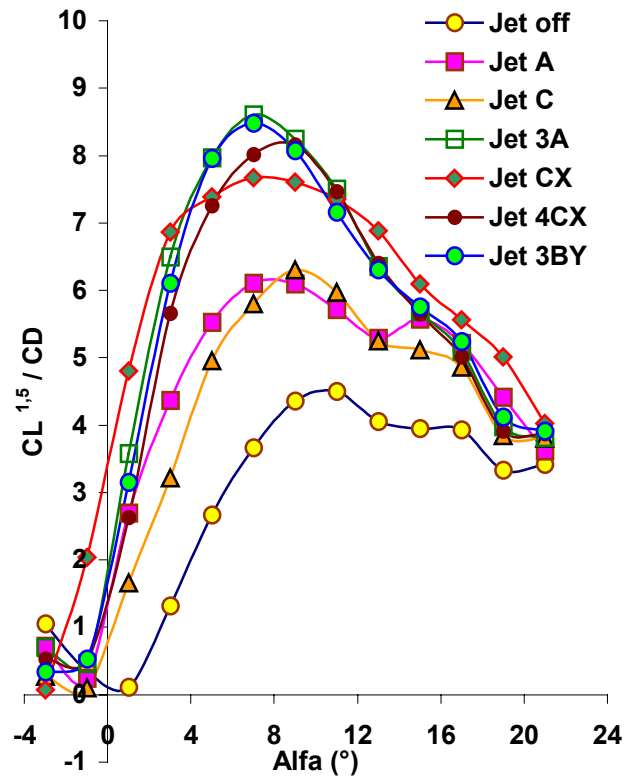

Figure 17 Climb rate factor results of the best configurations.

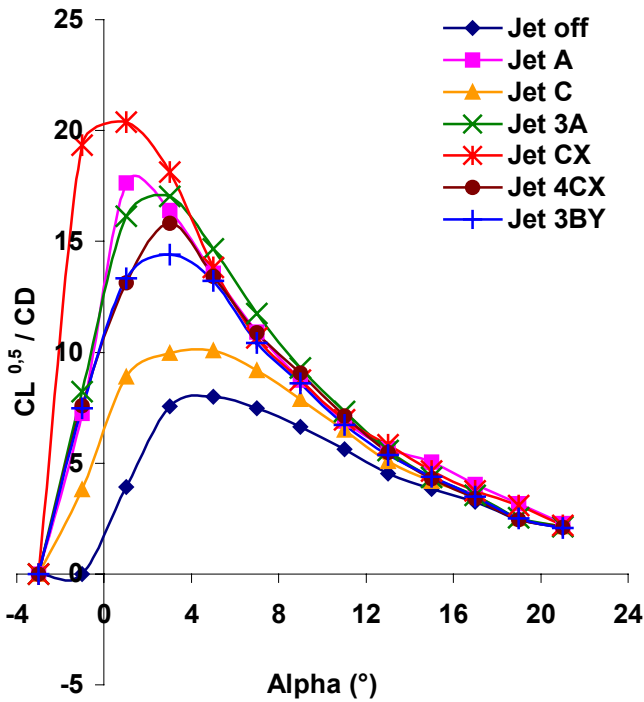

Figure 16 maximum range factor results of the best configurations.